

# Engine Peak Meter

Type 2516B1/B12

## Cylinder pressure measuring instrument for gas and diesel engines

The Engine Peak Meter Typ 2516B... is a rugged measuring instrument for monitoring engines with a speed of up to 4 000 min<sup>-1</sup>. The software for data evaluation contained in the included accessories allows changes in peak pressure to be shown graphically and recorded.

- Immediate on-site data evaluation
- Rechargeable battery
- Software for data evaluation included
- Easy to operate



### Description

The battery-operated measuring instrument measures between 1 and 100 pressure cycles from which it calculates the arithmetic average values of the peak pressure, standard deviation, maximum gradient of the pressure curve as well as the average pressure curve. The numeric data are shown on the LC display and can be saved as required. The average pressure curve plotted can be analyzed with the software for data evaluation contained in the included accessories. Since long indicator pipe cause gas oscillations which falsify the measuring signal, the cylinder pressure signal can be smoothed with an adjustable low-pass filter. The measurement data can be stored in two areas of the memory, each of which holds 20 records ("As found"/"As left"). This enhanced functionality makes the new engine peak meter ideal for balancing the cylinders of gas and diesel engines.

An additional measuring function allows the peak pressure to be displayed without time limitation and sending the analog sensor signal at the monitor output.

### Application

For indicator valve measurements, the sensor Type 6619AP35 is installed in adapter Type 6513AK. This very precise sensor has proved to be ideal in industrial applications. The sensor Type 6619AP35 is contained in the measuring set (in a case) Type 2516B12.

### Technical data/electronics

Measuring range		
Type 2516B1	bar	0 ... 350
Input voltage range		
Type 2516B1	V	1 ... 15
Sensor sensitivity (adjustable)	mV/bar	7 ... 40
Accuracy of the pressure value display	%	≤±0,5
Resolution	bar	0,1
Range of engine speed	min <sup>-1</sup>	50 ... 4 000
Operating temperature range	°C	0 ... 50
Number of pressure cycles (adjustable)	–	1 ... 100
Low-pass filter (5th order Butterworth)	Hz	300, 500, 1 500, 5 000
Number of data memories		2
Memory capacity per memory	Data record <sup>1)</sup>	20
Sampling rate per revolution	–	720
LCD graphic display	Dots	128x64
Monitor output	–	BNC neg.
Output (Monitor)	V	5
USB interface	–	2,0
Dimensions Type 2516B1	mm	183x92x45
Dimensions Type 2516B12 (case)	mm	452x327x100
Weight	g	350
Battery rechargeable	NiMh	9V, 250m/Ah
Operating time	h	>4
Charging time	h	<4

<sup>1)</sup> A data record consists of numerical measurands, curve trace, number, date and time of the memory location

2516B\_003-472e-10:19

**Measuring functions**

- $p_{max}$  Maximum peak pressure
- $p_{min}$  Minimum peak pressure
- $p_{av}$  Average peak pressure
- $S_{dev}$  Standard deviation of the peak pressure
- $dp/ca$  Maximum gradient of the pressure curve
- r/min Speed
- $p_{peak}$  Current peak-pressure; measuring function unlimited in time

**Auxiliary function**

- $p_{av}$  Average cylinder peak pressure value  $p_{av}$  of the engine  
This value is calculated from  $p_{av}$  stored in the memory block 1. The calculated value is displayed and instantly updated as new data is entered.

**Software**

These pressure curves can be displayed graphically by means of Windows Software contained in the included accessories. The pressure curves of all cylinders can be overlapped – a feature for verifying the cylinder balancing of the engine.

**Auxiliary functions**

Setting of all measuring parameters is done via the build-in keyboard and display.

**Monitoring functions**

Battery display with symbol; the Engine Peak Meter switches off automatically 2 minutes after the last button actuation unless this function is deactivated.

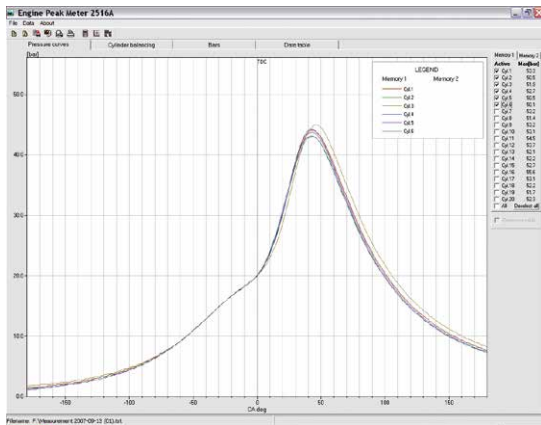

Fig. 1: Cylinder pressure curves of a 6-cylinder gas engine, before and after the maintenance work ("as found" / "as left")



Fig. 3: Cylinder peak pressure deviation  $p_{av}$  of each individual cylinder compared to the calculated average peak pressure of the engine, before and after the maintenance work ("as found" / "as left")

Cylinder	p <sub>max</sub> [bar]		p <sub>min</sub> [bar]		p <sub>av</sub> [bar]		S <sub>dev</sub> [bar]		dp/ca [bar/deg]		r/min		p <sub>peak</sub> [bar]	
	as found	as left	as found	as left	as found	as left	as found	as left	as found	as left	as found	as left	as found	as left
CA1	95.1	95.1	35.8	35.8	45.1	43.3	1.8	1.07	51.7	51.4	36.1	48.1	37.9	37.9
CA2	95.1	95.1	36.1	44.1	37.9	42.9	1.8	1.07	51.7	51.7	36.1	45.1	37.9	37.9
CA3	95.1	95.1	37.1	45.1	37.9	42.9	1.8	1.05	54.0	54.0	37.1	45.1	43.9	42.9
CA4	95.1	95.1	36.1	45.4	43.9	42.9	1.8	1.05	50.6	50.6	37.1	45.1	37.9	37.9
CA5	95.1	95.1	36.1	44.7	34.9	42.9	1.6	1.05	51.7	51.7	36.1	45.1	36.9	37.9
CA6	95.1	95.1	36.1	44.1	34.9	42.9	1.6	1.05	52.1	52.1	37.1	45.1	41.9	42.9

Fig. 2: Data table with the numeric values, before and after the maintenance work ("as found" / "as left")



Fig. 4: Bar diagram

2516B\_003-472e-10-19

**Ordering code and accessories included**      **Type/Mat. No.**

**Engine Peak Meter Type 2516B1**

(Instrument only)

- Software for data evaluation      7.642.025

**Engine Peak Meter Type 2516B12**

(Kit with sensor and measuring set in case)

- Cylinder pressure sensor with Piezotron amplifier      6619AP35
- Adapter for connection to indicator valve      6513AK
- Tubular socket wrench      1377
- Battery charger      5.510.293
- Case      3.070.219



Fig. 5: Scope of delivery Type 2516B12

**Description type 6619AP35**

Precision sensor for periodic measurement at the indicator valve. Very good thermodynamic behavior.

- High measuring accuracy
- High temperature stability
- Robust design



Fig. 6: Sensor Type 6619AP35

**Technical data/sensor**

Range	bar	0 ... 350
Overload	bar	450
Sensitivity ±1 %	mV/bar	13
Natural frequency	kHz	≈90
Linearity, all ranges	%FSO	≤±0,5
Operating temperature range		
Front part of sensor	°C	-50 ... 350
Hex-nut to connector	°C	-50 ... 150
Electronics in the plug	°C	-50 ... 90
Time constant at 350 °C	s	>100
Connector		Type Fischer SE 103 pos.

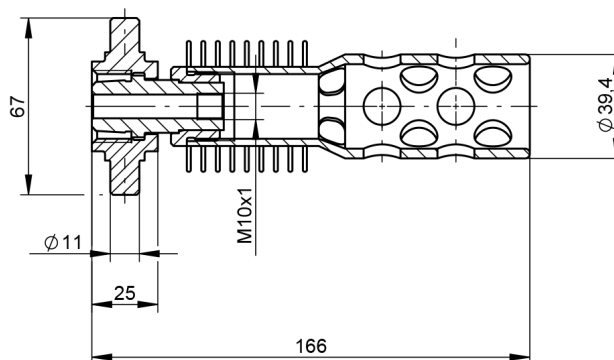

Fig. 7: Thompson-Adapter Type 6513AK

Further technical data and information see data sheet 6619AP35 Doc. No.003-398e.

Windows is a registered trademark of Microsoft Corporation

Viton is a registered trademark of DuPont Performance Elastomers