

MSW DTI sensors

Type 5612A...

Universal measurement steering wheels

For non-contact measurement of steering moment, steering angle and steering speed.

- Non-contact, optical steering angle sensor
- 50 N·m version for passenger cars
250 N·m version for utility vehicles
- Small size
- High dynamics
- Preservation of airbag function
- Fast and easy installation

Description

MSW DTI sensors are specifically designed to be used with modern steering wheels of passenger cars and utility vehicles. The introduction of new driving assistance systems calls for testing equipment that performs even better. MSW DTI sensors meet the growing demands of modern automotive engineering perfectly. They offer high dynamics and excellent resolution without impairing steering wheel functions (airbag) and control elements.

MSW DTI sensors may be mounted in two different ways: normally the sensor is installed between the steering wheel and the steering shaft. To permit universal application, the sensors may be equipped quickly and easily with an interchangeable adapter to connect to the steering shaft gearing. An optional steering angle stop improves the performance of special driving maneuvers.

MSW DTI sensors are equipped with a switch-key to reset the steering moment and angle. The offset is stored and still available after voltage loss or restart. Via CAN bus, outputs can be set to zero at any point. Calibration data are stored in the sensor element, enabling the user to exchange sensor elements, if required.

An optional steering angle stop improves the performance of special driving maneuvers.

Application

Universal measurement steering wheel for measurement of steering moment, steering angle and steering speed; for vehicle driving dynamics tests like ISO 4138, steady-state circular course drive.

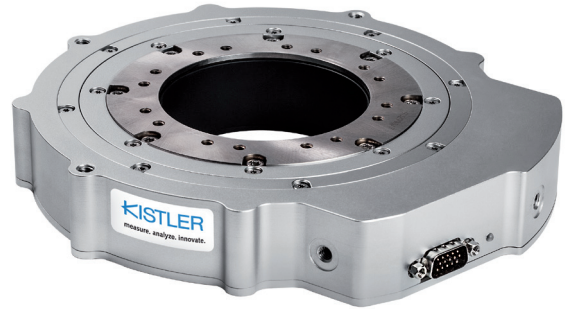

DTI technology

End-to-end bus wiring system to take the measurement signals from every sensor to the data recorder. DTI converts each signal into a unique, time stamped digital output either directly in the DTI sensors, or via suitable DTI converters for use with any existing sensors. The sensor data is collected at the central DTI logger and is transmitted via Ethernet to the computer for evaluation. A single cable is all that is needed to configure the sensors, to transmit and synchronize the measurement data and to supply power. The automated sensor detection simplifies the test setup: installation position, calibration values and relevant physical parameters are detected automatically by the measuring software (KiCenter) and can be configured using the GUI.

Technical data

Performance specifications

Power supply	V	10 ... 28
Power consumption at 12 V	W	<20
Adjustable filter time	ms	2 ... 512 (or unfiltered)
Measurement frequency	Hz	1,000
Temperature ranges		
Nominal temperature range	°C	0 ... 70
Operating temperature range	°C	-20 ... 80
Degree of protection		
Sensor (cable mounted)		IP40
Electronics (cable mounted)		IP40
Mass moment of inertia	kg·cm ²	80
Weight (without steering wheel and electronics)		
Passenger car version ¹⁾	kg	2.7
Commercial vehicle version ¹⁾	kg	2.8

Steering moment

Measurement range			
Passenger car	N·m		±50
Commercial vehicle	N·m		±250
Overload			
Passenger car torque	N·m		±100
Passenger car bending moment	N·m		±150
Commercial vehicle torque	N·m		±500
Commercial vehicle bending moment	N·m		±750
Accuracy	%FSO		±0.15
Linearity deviation	%FSO		±0.15
Temperature influence			
On the zero signal	%FSO/10K		0.5
On the index value	%FSO/10K		0.5
Zero-point stability (above 24 h)	%FSO		0.05

Steering angle

Measurement range (absolute principle)	°	≥±1,250
Steering speed	°/s	≤2,000
Resolution	°	0.015
Accuracy	°	±0.1

Steering wheel adaptation

Diameter of the hollow shaft	ø mm	75
Max. height of the measuring body	mm	33
Pitch circle for screw-on threads (M4/16 pcs)	ø mm	90

Signal outputs ²⁾

Analog outputs		
DA converter resolution	Bit	16
Non-linearity	LSB	±16
Steering moment M1 (±50/250 N·m) ³⁾	V	-10 ... 10
Steering moment M2 (±10/50 N·m) ³⁾	V	-10 ... 10
Steering angle L1 (±1 250 °) ³⁾	V	-10 ... 10
Steering angle L2 (±200 °) ³⁾	V	-10 ... 10
Steering speed (±1 000 °/s) ³⁾	V	-10 ... 10
Digital outputs		
Steering moment TTL		yes
Steering angle TTL		yes
Steering speed TTL 0 °	pulses/rev	20,000
Steering speed TTL 90 °	pulses/rev	20,000

Interfaces

CAN (Motorola/Intel)	2.0B
USB (Full Speed)	2.0
Ethernet	yes
DTI	yes

¹⁾ With standard steering wheel flange, without steering wheel and steering shaft adapter

²⁾ All outputs are protected against overvoltage and short-circuit

³⁾ Standard settings; can be individually adjusted via KiCenter

Dimensions of the sensor element

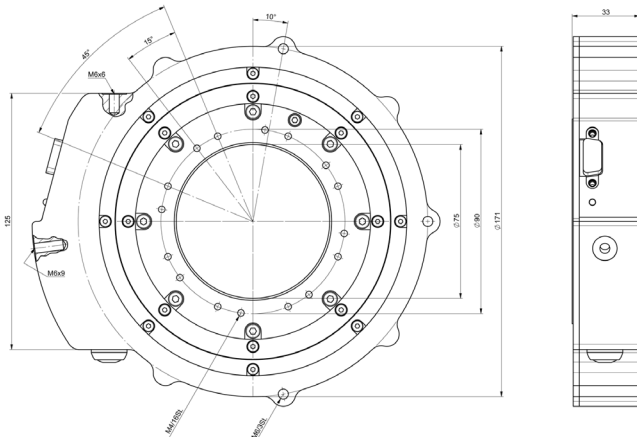

Fig. 2: MSW DTI sensor electronics

Dimensions of the sensor electronics

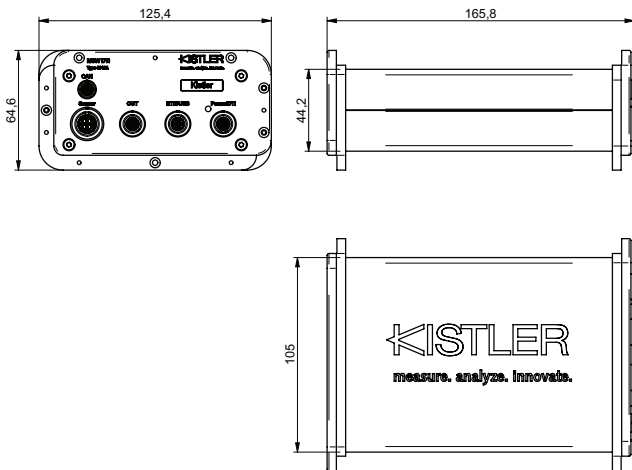

Fig. 3: Dimensions of the MSW DTI sensor electronics

Optional accessories: steering angle stop

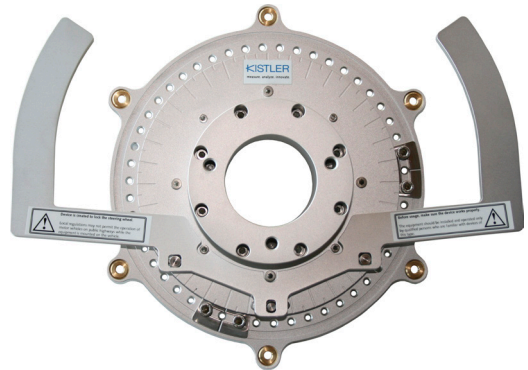

Fig. 4: Steering angle stop for MSW DTI sensors

Features of the steering angle stop:

- Fixes the steering angle to a pin point
- Enables steering movement between two different steering angles
- Easy handling
- Use of existing steering shaft adapters is possible
- Unrivaled mechanical setup (size and height)

Typical applications:

- Sudden steering input
- Sinus steering
- Zero-point determination

Optional accessories: 1-point suction holder

For fixing the stator at the windshield.



Fig. 5: 1-point suction holder (car), Art. No. 18025571

5612A_003-394e-02.19

Included accessories

- Connecting cables
 - CAN, l = 2 m
 - USB, l = 1.8 m
 - DTI, l = 0.5 m
 - ETH, l = 2 m
- Power cable DTI sensors, l = 2 m
- Distributor cables
 - KiMSW LEMO OUT Ana, l = 1 m
 - KiMSW LEMO OUT Dig, l = 1 m
- USB stick software and manuals
- Adapter VGA connector/socket 90°
- Transport case complete with inlays

Optional accessories

- Steering wheel adapter ø280 ... 420 mm
- Steering wheel adapter ø400 ... 560 mm
- 1-point suction holder for mounting at the windshield (car)
- 1-point suction holder for mounting at the windshield (truck)
- Kistler angle lock adaptation with basic set
- Transport case sensor body + inlays, small
- Custom adaptations

Ordering no.

55155606
55155609
55155607
55155608
55155612

55181949
55181959
55158846
55120394
55066887

Ordering no.

22001141
22001142
18025571
18029307
18026445
55120723
on request

Ordering key**Sensor element**

50 N·m *	1
250 N·m	2

Steering wheel

Without steering wheel	0
360 mm for 50 N·m *	1
390 mm for 250 N·m	2
450 mm for 250 N·m	3

Sensor cable

5 m *	1
10 m	2

Interface

±10 V	1
-------	---

*Standard configuration

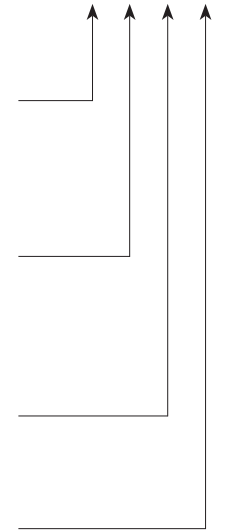
Type 5612A **Ordering example****Type 5612A1111**

MSW DTI sensor element 50 N·m measurement range, with 360 mm steering wheel, 5 m cable, ±10 V (standard configuration)