

# PiezoStar Pressure Sensor

## For high precision measurements of large bore engines

New generation of uncooled high-temperature pressure sensor with tuned thermodynamic characteristics for measurement at the indicator valve of low and medium speed engines.

- Available with Piezo Smart Technology
- Very stable sensitivity across temperature range
- Max. temperature 400 °C
- 350 bar

### Description

Type 6019A ... piezoelectric cylinder pressure sensor uses a Piezo Star crystal which guaranties very low thermal sensitivity deviation and excellent linearity. The low thermal shock error and the stable sensitivity across the full temperature allow cylinder pressure measurements with high precision even under unstable load conditions. The sensor and the connector are connected by a strong, temperature resistant cable with fluorelastomer coating.

This new technology also enables the sensor to cope with operating temperatures of 400 °C for a limited time (<20 min.) this allows measurements at the indicator valve of 4-stroke engines.

### Piezo Smart

This sensor is available with Piezo Smart technology. The Piezo Smart automatic sensor Identification is an active system for identifying individual piezoelectric cylinder sensors. The system is based on the IEEE 1451.4 standard and is used for automatically setting the parameters of the measuring chain.

### Application

Type 6019A ... is mainly used for periodically cylinder pressure measurements at the indicator valve of low speed and medium speed engines. It makes it possible to do thermodynamic investigations under harsh industrial conditions.

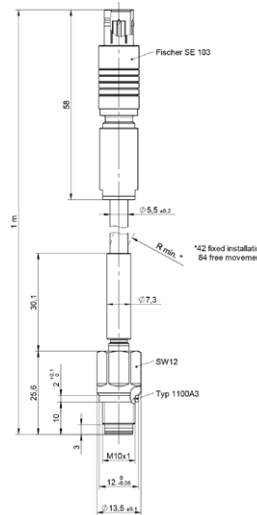

Type 6019A



### Technical data

Measuring range	bar	0 ... 350
Calibrated partial range with RT, 150 °C, 250 °C, 350 °C	bar	0 ... 150, 0 ... 250
Overload	bar	450
Sensitivity	pC/bar	30
Natural Frequency	kHz	65
Linearity, all ranges @ 23 °C	%FSO	≤±0,3
Acceleration sensitivity		
Axial	bar/g	<0,002
Radial	bar/g	<0,0002
Operating temperature range		
Continuous	°C	-40... 350
short time (< 20 minutes)	°C	-40... 400
Sensitivity shift @ 250 °C ± 100 °C	%	±0,7
Thermal shock error (at 1 500 1/min, IMEP = 9 bar)		
Δp (short-term drift)	bar	≤±0,5
ΔIMEP	%	±1,5
Insulation resistance @ 23 °C	Ω	10 <sup>13</sup>
Tightening torque	Nm	15
Weight (with cable)	g	165
Connector		
6019A000		10-32UNF
6019A_0	Fischer	SE103, male
6019A_S	Fischer	SE103, female

6019A\_003-390e-08.18

**Mounting**

In order to minimize thermal stress on the sensor, it should be located so that good heat dissipation to colder components is possible. This can normally be achieved by a set-back location. Optimum sensor life is achieved at an average temperature of 200 ... 300 °C in the sensor body. An angled gas channel can also reduce the effect of flame on the diaphragm, and thereby minimize the short term drift of the sensor. In order to prevent pipe oscillations, the lengths of the gas channel should not exceed 30 mm. Strong gas oscillations occur when the gas column between sensor and combustion chamber resonates. Superimposed on the cylinder pressure, these pressure oscillations impose an additional load on the sensor, resulting in reduced life of the sensor.

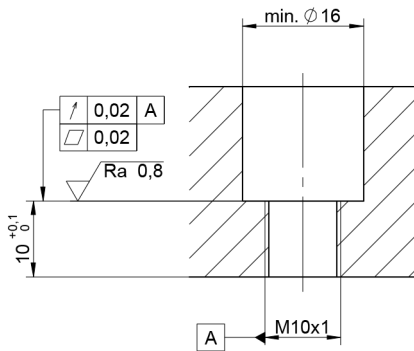

Fig. 1: Mounting bore (4-stroke application) for flush mounting

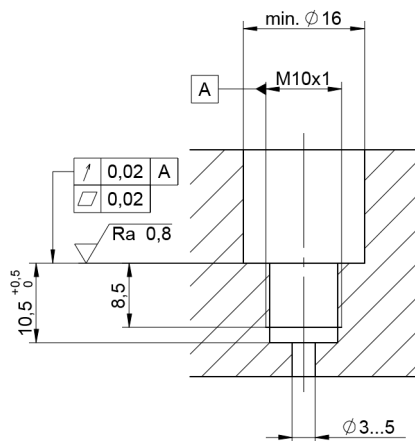

Fig. 2: Mounting bore (4-stroke application) for recessed mounting with additional gas channel. Admissible bore length depends on the application. Too long bore may interfere the quality of the measuring results

**Ordering key**

Type 6019A

**Cable**

without cable	0
with cable	1

**Cable type**

without cable	0
FPM, Ø 5,5 mm, 1m	1

**PiezoSmart**

without PiezoSmart	0
with PiezoSmart	S

**Installed in Thompson adapter**

No Adapter	-
6513A	A
6513AK	K

Example:

Sensor with FPM cable 1m, PiezoSmart, no Adapter = 6019A11S

6019A\_003-390e-08.18

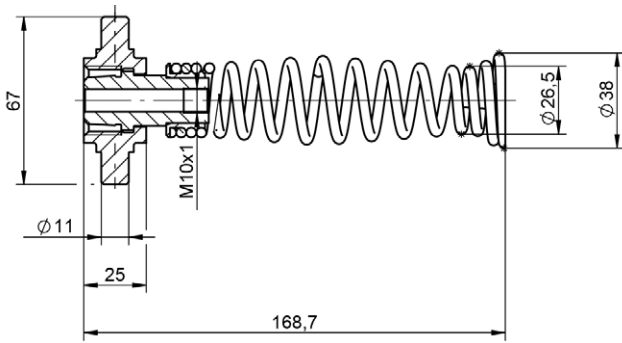

Fig. 3a: Thompson adapter Type 6513A

**Accessories**

- Nickel seal
- Thompson adapter
- Thompson adapter with cooling fins

**Type**

- 1100A3
- 6513A
- 6513AK

**Mounting accessories**

- Torque wrench 8 ... 40 N·m
- Fork wrench hex. 18 mm for torque wrench
- Tubular socket wrench hex. 14 mm for Ø18 mm fitting hole
- Special key for Thompson adapter Type 6513A

**Type**

- 1300A11
- 1300A13
- 1300B6
- 1300A1

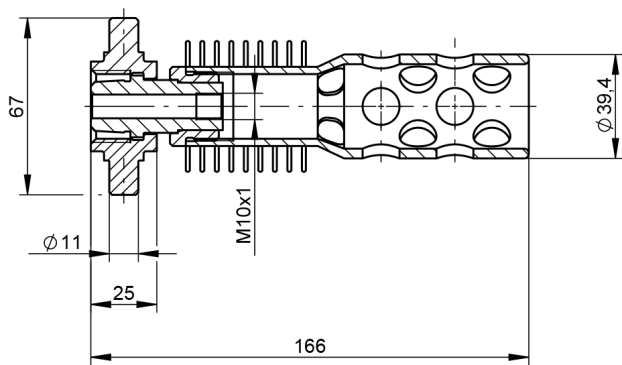

Fig. 3b: Thompson adapter with cooling fins Type 6513AK

6019A\_003-390e-08.18