

Upper Neck Load Cell

Type M55596A...

Six-axial

Type M55596A... is designed to measure forces and moments in the upper neck of the Thor-M (TH) crash test dummy.

- Six-axial (F_x , F_y , F_z , M_x , M_y , M_z)
- UPS module available
- Low linearity errors and hysteresis errors
- Kistler system cabling
- Polarities according to SAE J211/1



Type M55596A... with cap

Description

The load cell is made of elements on which forces and moments are transmitted. The mechanical deformation element, applied with strain gage, serves for mechanical electrical deformation. The effectiveness of the load cell resembles the behavior of a spiral spring. The forces to be measured create mechanical stretches and buckling in the gaging member. In order to avoid linearity errors, the deformation paths are constructively held small (high rigidity).

Thus a proportional behavior is realized. The force and moment proportional resistance variations are measured by a Wheatstone-type bridge circuit. The load cell is available with UPS module which is integrated in an external housing in the wiring or in the connector. Customized cable lengths and connectors with specific pin assignments are optionally available.

Technical Data

Axial Data		F_x	F_y	F_z	M_x	M_y	M_z
Measuring range	kN	8,9	8,9	13,3			
	N·m				284	284	284
Bridge output voltage (typ.)	mV/V	2,0	2,0	1,1	1,6	1,6	1,6
Sensitivity (typ.)	$\mu\text{V}/\text{V}/\text{kN}$	223	223	85			
	$\mu\text{V}/\text{V}/\text{N}\cdot\text{m}$				5,7	5,7	7,9
Bridge resistance	Ω	350	350	700	350	350	350
Ultimate load	%	150	150	150	150	150	150

General Data

Supply voltage ¹⁾	VDC	2,5 ... 15
Insulation resistance ²⁾	G Ω	>10
Operating temperature range	$^{\circ}\text{C}$	-20 ... 80
Storage temperature range	$^{\circ}\text{C}$	-30 ... 90
Amplitude non-linearity (typ.)	%	<1
Hysteresis (typ.)	%	<1
Channel cross talk	%	<5
Bridge zero output (typ. / max.)	mV/V	0,01 / 0,03
Weight (without cable)	grams	462

All specifications are typical at 25 $^{\circ}\text{C}$ and rated at 10 V sensor supply voltage, unless otherwise specified.

¹⁾ With UPS module 9 ... 12 VDC

²⁾ All wires to load cell housing, measured with 500 VDC

Application

The load cell is directly assembled at the designated location in the dummy and provides important information about the loads on the human body occurring during a crash test.

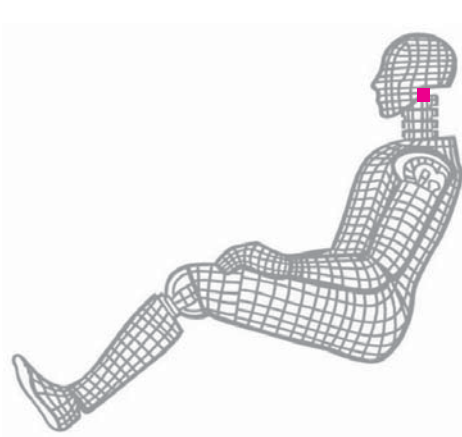

Fig. 1: Dummy application, location upper neck

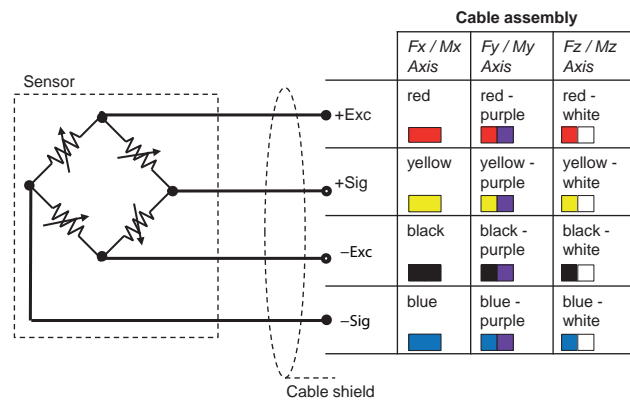

Fig. 2: Cable assembly

Included Accessories

- None

Optional Accessories

- Add. label with serial number, plug side
- UPS module
- Add. label with ID number at sensor
- Add. shunt

Type No.

M015KABID
on request
M015KABID
on request

Ordering Key

Type M55596A

Design

Standard	FM
----------	----

Cable Length before Electronics

0 cm	00
<10 cm (digit x 1 cm)	C#
10 cm ... 9,9 m (digit x 10 cm)	##
10 m ... 90 m (digit x 10 m)	D#

Additional Electronics

Sensor detail, as per type declaration force-moment TP-650-2	#
--	---

Cable Length after Electronics

0 cm	00
<10 cm (digit x 1 cm)	C#
10 cm ... 9,9 m (digit x 10 cm)	##
10 m ... 90 m (digit x 10 m)	D#

Connector

Conn. type, as per TP-600	#-
Conn. type assignment, as per TP-600	-#

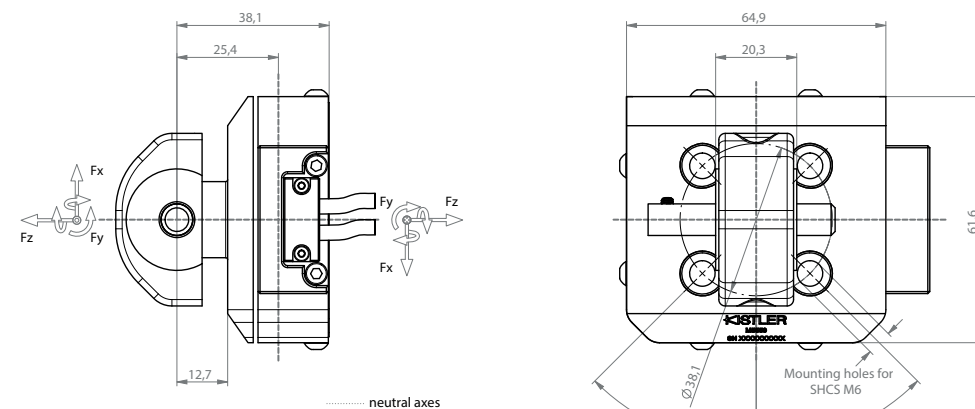

Fig. 3: Dimensions in mm

M55596A_003-226e-10.15

This information corresponds to the current state of knowledge. Kistler reserves the right to make technical changes. Liability for consequential damage resulting from the use of Kistler products is excluded.