

# Torsion Proof Miniature Coupling

## Single-flexible with Clamping Hub

Type 2302A...

Torsion proof miniature coupling for self-supporting installation of torque sensors without fix mounting support into the shaft assembly.

- High speed range
- Low weight, low moment of inertia
- High torsion resistance
- Free of wear and maintenance
- Non-corroding
- Antimagnetic

### Description

Miniature couplings Type 2302A... are torsionally rigid, but angularly and axially flexible. The flexible disc or disc assembly is connected alternately to both hubs by rivets.

Axial and angular misalignment of the shaft assembly can be applied in that way.

Both supporting parts (hubs) are made of light metal alloy. Miniature couplings Type 2302A... are therefore characterised by low weight, low moment of inertia and are non-corroding and antimagnetic.

If couplings are properly selected, duly assembled and used, the lifetime is nearly unlimited.

### Dimensions

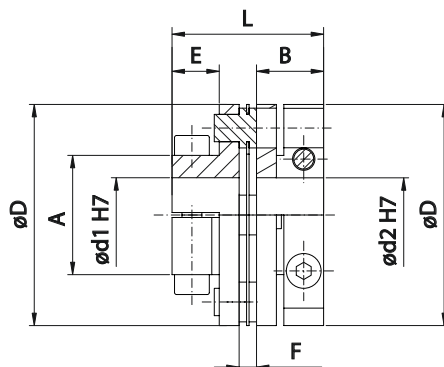

### Application

Two single-flexible couplings provide compensation, when torque sensors must be installed self-supporting into a shaft assembly. Compensation of misalignment is always needed to avoid measurement error and damage to the sensor. If a single-flexible coupling is mounted to each side of the sensor, also radial misalignment can be compensated for. Dependent on angular misalignment and overall length, this assembly in sum results in a full coupling. Each coupling is mounted via clamping hubs on both halves.

Inside diameters ( $\varnothing d1$  and  $\varnothing d2$ ) of the clamping hubs can be configured individually. This allows integrating the torque sensor into nearly any application.

Type 2302A...		25	37	50	62	75
Nominal torque	$T_{KN}$ N·m	0,39	1,56	6,17	24,7	36,2
$\varnothing D$	mm	25,4	35,8	44,5	57,4	64
Hole diameters $\varnothing d1/\varnothing d2$ (min. ... max.)	mm	3 ... 10	4 ... 14	6 ... 18	10 ... 24	12 ... 28
A	mm	13	19	24	30	34
B	mm	9	13,2	13,4	16,1	18
E	mm	6,6	10	9,4	11,1	13
F	mm	2,2	2,7	3,6	4,4	5
L	mm	20,2	29,1	30,4	36,6	41

**Technical Data**

Type 2302A...			25	37	50	62	75
Nominal torque	$T_{KN}$	N·m	0,39	1,56	6,17	24,7	36,2
Max. torque	$T_{Kmax}$	N·m	0,54	2,19	8,64	34,6	50,7
Permitted axial offset	$\Delta K_a$	mm	0,8	0,8	0,8	0,8	0,8
Permitted angular offset	$\Delta K_w$	°	2	1,5	1	0,7	0,7
Rotary spring rate x 10 <sup>-6</sup>	$C_{Tdyn}$	N·m/rad	3,89	25,986	39,768	103,572	161,76
Max. speed	$n_{max}$	rpm	64 000	44 000	36 000	28 000	24 000
Moment of inertia <sup>1)</sup>	J	10 <sup>-6</sup> ·kg·cm <sup>2</sup>	1,83	11,1	28,56	78,61	159,4
Mass <sup>1)</sup>	m	kg	0,022	0,062	0,1	0,195	0,278
Hole diameters $\varnothing d1/\varnothing d2$ (min. ... max.) <sup>2)</sup>	mm		3 ... 10	4 ... 14	6 ... 18	10 ... 24	12 ... 28

<sup>1)</sup> Moment of inertia and mass relative to hubs with maximum hole size.

<sup>2)</sup> Please specify desired hole diameters with order.

Maximum misalignment values of  $\Delta K_a$  and  $\Delta K_w$  can be utilized at the same time.

**Included Accessories**

- All necessary bolts for coupling assembly are included

**Example of Application**

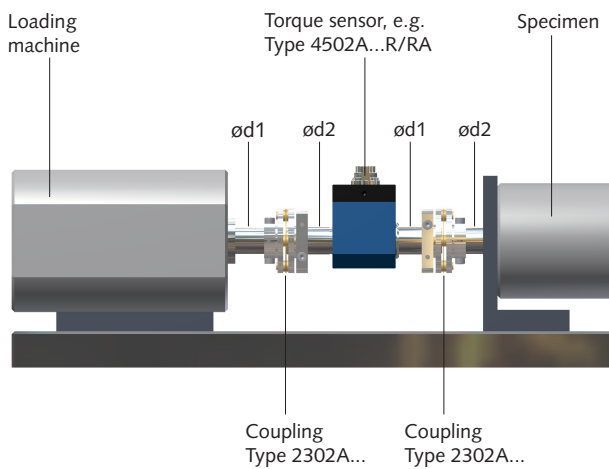

**Ordering Key**

Type 2302A  sp

**Coupling Size**

Nominal torque 0,39 N·m	25
Nominal torque 1,56 N·m	37
Nominal torque 6,17 N·m	50
Nominal torque 24,7 N·m	62
Nominal torque 36,2 N·m	75

Please specify desired hole diameters  $\varnothing d1$  and  $\varnothing d2$  with order (additional plaintext). Observe of min. and max. diameters (see dimensions table).

**Ordering Example:**

Torsion proof miniature coupling, size 37.  
Hole diameters  $\varnothing d1 = 10$  mm,  $\varnothing d2 = 12$  mm.

Type 2302A37sp

2302A\_000-671e-05.08