

MN Press Force Calibration Sensor

Type 9931A...

Sensor for Measuring Large Compression Force

Piezoelectric sensor for measuring quasistatic and dynamic compression forces in the meganewton range. This series of calibration sensors is designed for measuring compression forces in large industrial presses.

- Extremely wide measuring range suitable for compression forces from kilonewtons to meganewtons
- Calibrated at intervals of 10 % of the measuring range (FS) as standard
- High overload capacity
- Manual handling possible
- Accessories available for optimizing mounting and force application

Description

The force to be measured is transferred to the quartz sensor elements by means of a cylindrical deformation element made of high strength steel. These elements output an electrical charge proportional to the mechanical load. An amplifier converts the charge into a proportional voltage signal of, for example, 0 ... ± 10 V at FS.

"Replaceable cover plates" Type 9588A0... are fitted to the contact surfaces of the sensor. They are readily replaced if there are noticeable signs of wear.

Although generally heavy, in most cases the sensors can be handled without any equipment. Two eye bolts (transport bolts) for securing the sensors and tapered flanges to a lifting device are included in the equipment supplied.

Two or more sensors can be combined depending on the application. The maximum force measurable can be increased by using the sum signal from calibration sensors connected in parallel.

Loading the calibration sensor with a 100 % FS compression force produces a pressure of approximately 400 N/mm^2 on the bearing surface of the Type 9588A0... cover plates. This relatively high load on the press components can be reduced to a maximum of 100 N/mm^2 by using the Type 9588A3... tapered flanges.



Applications

The meganewton press force calibration sensors are used for the following applications:

- Checking and/or calibrating compression forces in mechanical or hydraulic presses
- Measuring the force distribution in large presses. Determining the deviations caused by eccentric force application.
- Mobile force link for in-situ testing and calibration.

Technical Data

	Type	9931A1	9931A2	9931A3	9931A4
Measuring range					
Compression force F_z	kN	50 ... 2 500	50 ... 5 000	100 ... 10 000	100 ... 20 000
Tonne-force	t	5 ... 250	5 ... 500	10 ... 1 000	10 ... 2 000
Calibrated ranges (calibrated at intervals)	%FS	10, 20, 30, 40, 50, 60, 70, 80, 90, 100			
Calibration procedure		(*)	(*)	(*)	(**)
Overload					
Compression force 130 %FS	kN	3 250	6 500	13 000	26 000
Sensitivity (nominal)	pC/kN	≈-14	≈-10	≈-7	≈-5
Linearity	%FS	≤1,5	≤1	≤1	≤1
Crosstalk					
Shear force $F_x, F_y \rightarrow F_z$	%FS	≤4			
Bending moment $M_x, M_y \rightarrow F_z$	%FS	≤5			
Stiffness c_z (FEM calculated)					
without tapered flanges	kN/μm	5,1	7,4	11,5	17,4
with tapered flanges	kN/μm	4	4,5	7,7	11,8
Natural frequency f_{0z} (measured)					
without tapered flanges	kHz	≥3,3	≥3,8		
with tapered flanges	kHz	≥2,7	≥2,2		
Natural frequency f_{0z} (conversion factor)					
without tapered flanges	kHz			≥3	≥4
with tapered flanges	kHz			≥1,5	≥1
Natural frequency f_{0z} (FEM calculated)					
without tapered flanges	kHz	≥4,8	≥4,7	≥4,3	≥5,8
with tapered flanges	kHz	≥4,4	≥3,3	≥2,5	≥1,7
Surface pressure at FS referred to reference diameter (D_1/D_2 annulus)	N/mm ²	≤400			
Operating temperature range	°C	0 ... 70			
Degree of protection (EN60529)		IP65			
Plug connector		Fischer DBEE102 A 014-60 neg.			

Dimensions, Weight

Height H	mm	200	220	260	310
Outside diameter D_1	mm	120	144	192	262
Inside diameter D_2	mm	70	70	70	70
Pitch circle diameter D_3	mm	95	108	130	166
Dimension A	mm	20	20	25	30
Dimension B	mm	3	3	3	3
Weight	kg	14	22	46	100
Thread M	mm	M8	M10	M12	M16

* Calibration procedure according to DIN-EN10002-3. Calibration with mounted tapered flanges Type 9588A3x

** Calibration procedure according to DKD 3-9. Calibration with mounted tapered flanges Type 9588A3x

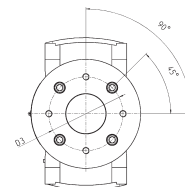
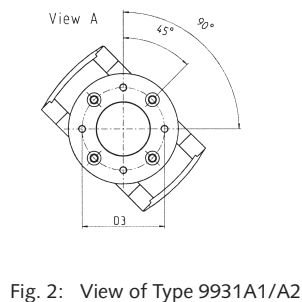
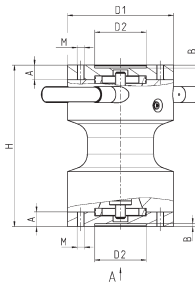

Fig. 1: Dimensions of Meganewton Type 9931A...

Fig. 2: View of Type 9931A1/A2

Fig. 3: View of Type 9931A3/A4

Dimensions of Type 9931A1/A2 with Mounted Tapered Flange Type 9588A31/A32 to Reduce the Loading Pressure at FS on the Surface of Pressplates to 100 N/mm² max.

	Type	9931A1	9931A2
Total height a	mm	320	430
Diameter b	mm	180	250
Height c	mm	60	105
Height d	mm	10	15
Diameter e	mm	120	144
Pitch circle diameter f (Mounting hole)	mm	150	200
Slotted hole length g for mounting screw	mm	9	11
Slotted hole breadth g for mounting screw	mm	18	35
Thread diameter i		M8	M10
Tap hole depth k	mm	16	20
Depth l	mm	70	105
Tap hole depth m	mm	20	20
Fixing screw n		M8x65/28	M10x100/32
Transport screw o (Art.No. 6.170.023/025)		M8x13	M10x17
Total weight	kg	32	56

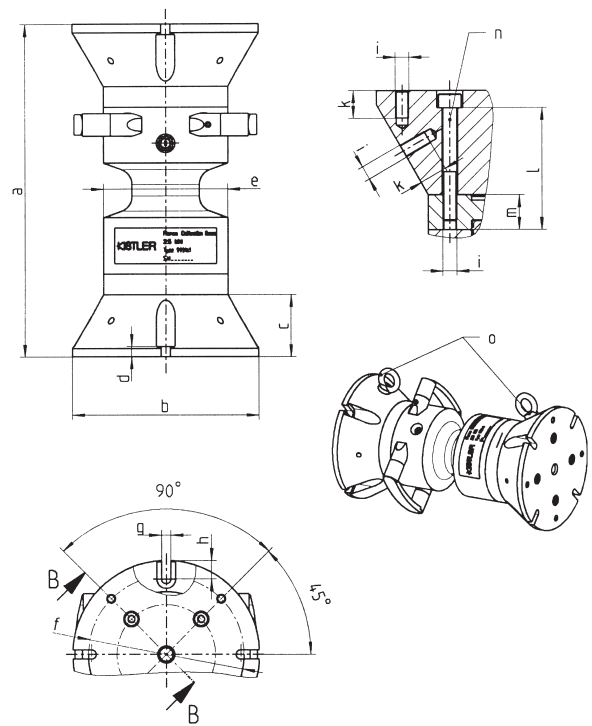

Fig. 4: Dimensions Type 9931A1/A2 with mounted tapered flange Type 9588A31/A32

Dimensions Type 9931A3/A4 with Mounted Tapered Flange Type 9588A33/A34 to Reduce the Loading Pressure at FS on the Surface of Pressplates to 100 N/mm² max.

	Type	9931A3	9931A4
Total height a	mm	580	810
Diameter b	mm	360	510
Height c	mm	160	250
Height d	mm	25	35
Diameter e	mm	192	262
Pitch circle diameter f (Mounting hole)	mm	300	400
Slotted hole length g for mounting screw	mm	13,5	17,5
Slotted hole breadth g for mounting screw	mm	55	80
Thread diameter i		M16	M24
Tap hole depth k	mm	30	40
Depth l	mm	165	245
Tap hole depth m	mm	25	30
Thread diameter n		M12	M16
Fixing screw o		M12x160/36	M16x240/44
Transport screw p (Art.No. 6.170.008/028)		M16x27	M24x36
Total weight	kg	210	590

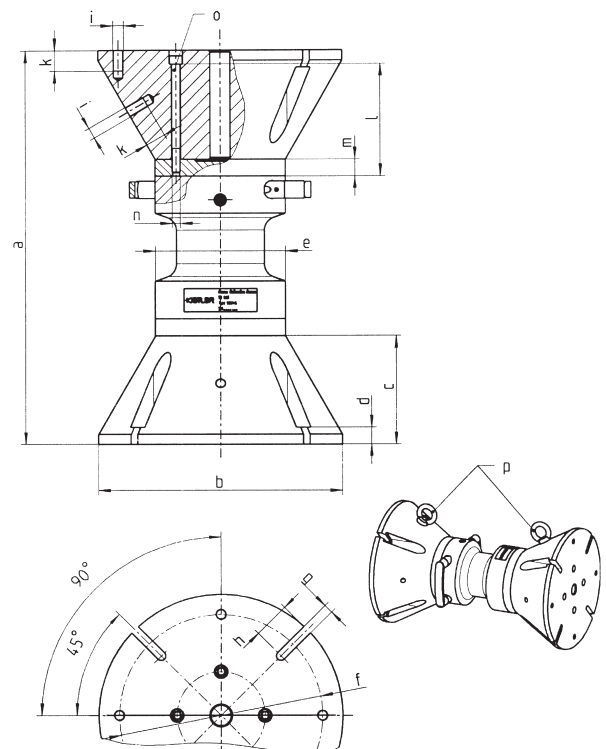

Fig. 5: Dimensions Type 9931A3/A4 with mounted tapered flange Type 9588A33/A34

3D CAD data can be downloaded
free of charge from
<http://kistler.partcommunity.com>

9931A_000-525e-08.18

System Description

Examples with Type 9931A2 (5 000 kN) press force calibration sensor

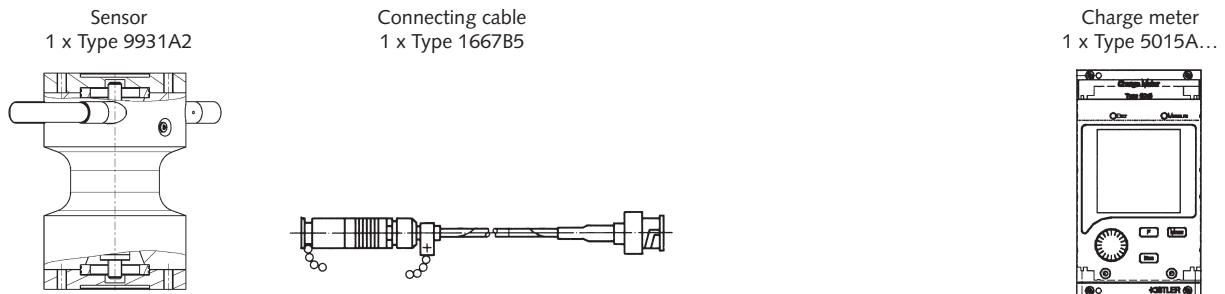

Fig. 6: Measuring chain with one sensor for total force of 5 000 kN

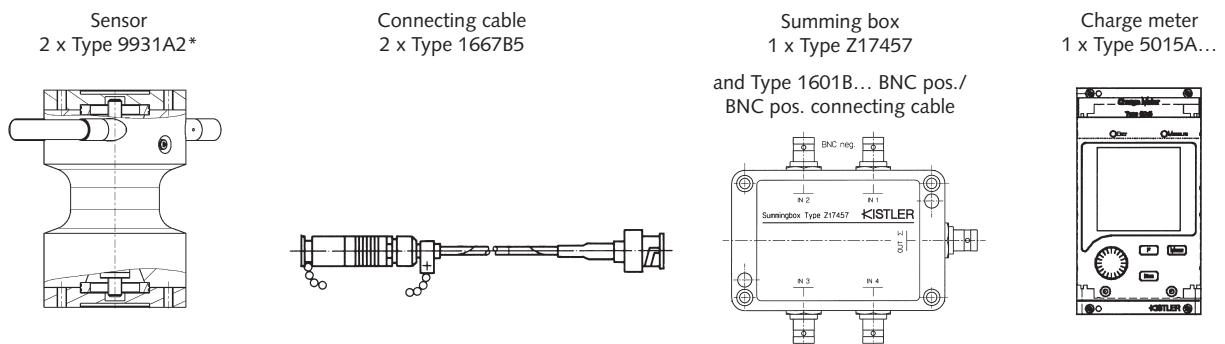

Fig. 7: Measuring chain with two sensors in parallel for total force of 10 000 kN

* Sensors ground to common height

Suggestions for further applications, e.g. measuring chain with several sensors in parallel with or without summation signal, on request.

Mounting

Type 9588A3... tapered flanges improve force application while reducing – at FS max – the pressure on the bed of the press to a maximum of 100 N/mm².



Fig. 8: Type 9931A2 (5 000 kN) meganewton press force calibration sensor

Accessories Included

- 2 pcs. M8 eyebolts for Type 9931A1
- 2 pcs. M10 eyebolts for Type 9931A2
- 2 pcs. M12 eyebolts for Type 9931A3
- 2 pcs. M16 eyebolts for Type 9931A4
- Calibration certificate
- Packing case

Art.No./Type

- 6.170.023
- 6.170.025
- 6.170.008
- 6.170.026

Optional Accessories

- Summing box
4 x BNC neg. to 1 x BNC neg.
- Connecting cable, $\varnothing 3,2$ mm, Viton®/
metal sheathed, l = 5 m,
Fischer SE102 A 014-11 pos./BNC pos.
- Connecting cable, $\varnothing 3,2$ mm, Viton®, l = 2 m, 1667B2
Fischer SE102 A 014-8 pos./BNC pos.
- Connecting cable, $\varnothing 3,2$ mm, Viton®, l = 10 m, 1667B10
Fischer SE102 A 014-8 pos./BNC pos.
- Connecting cable, $\varnothing 3,2$ mm, Viton®, l = 5 m, 1667B5
Fischer SE102 A 014-8 pos./BNC pos.
- Connecting cable, $\varnothing 3,2$ mm, Viton®, l = sp, 1667Bsp
Fischer SE102 A 014-8 pos./BNC pos.

Type/Art.No.

Z17457

1661A5

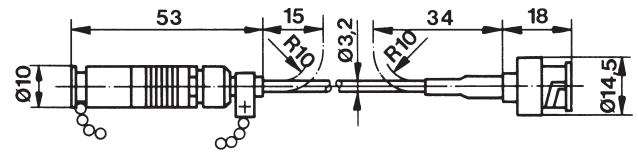

Fischer SE 102 A 014-11 pos.

BNC pos.

Fig. 9: Type 1667B5 connecting cable

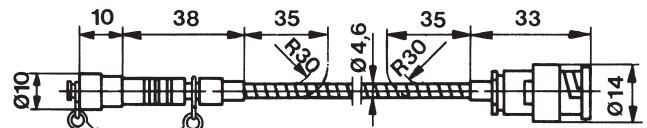

Fischer SE 102 A 014: 1835

BNC pos.: 1801

Fig. 10: Type 1661A5 connecting cable

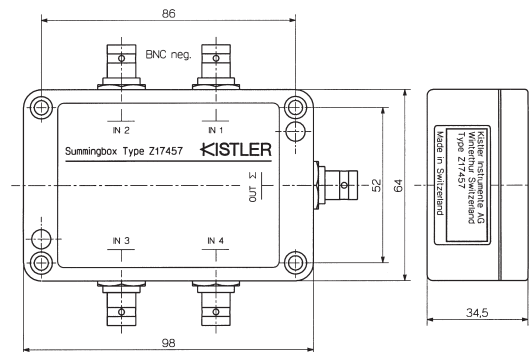

Fig. 11: Type Z17457 summing box

9931A_000-525e-08.18

Viton® is a registered trademark of DuPont Performance Elastomers.

Optional Mounting Accessories

MN Press Force Calibration Sensor

- Cover plate (spare part)
- Tapered flange
(Force application element for maximum surface pressure of 100 N/mm² at FS 100 %) plus included accessories:
- Fixing screw (4 pcs.)
- Eye bolt (2 pcs.)

Type

9931A1
9588A01
9588A31

6.120.088
6.170.023

MN Press Force Calibration Sensor

- Cover plate (spare part)
- Tapered flange
(Force application element for maximum surface pressure of 100 N/mm² at FS 100 %) plus included accessories:
- Fixing screw (4 pcs.)
- Eye bolt (2 pcs.)

9931A2
9588A02
9588A32

6.120.057
6.170.025

MN Press Force Calibration Sensor

- Cover plate (spare part)
- Tapered flange
(Force application element for maximum surface pressure of 100 N/mm² at FS 100 %) plus included accessories:
- Fixing screw (4 pcs.)
- Eye bolt (2 pcs.)

9931A3
9588A03
9588A33

6.120.061
6.170.026

MN Press Force Calibration Sensor

- Cover plate (spare part)
- Tapered flange
(Force application element for maximum surface pressure of 100 N/mm² at FS 100 %) plus included accessories:
- Fixing screw (4 pcs.)
- Eye bolt (2 pcs.)

9931A4
9588A04
9588A34

6.120.228
6.170.069

Mounting Solutions for Special Requirements

On request, appropriate solutions for mounting can also be worked out for special requirements, e.g. for integration and operation in a machine.

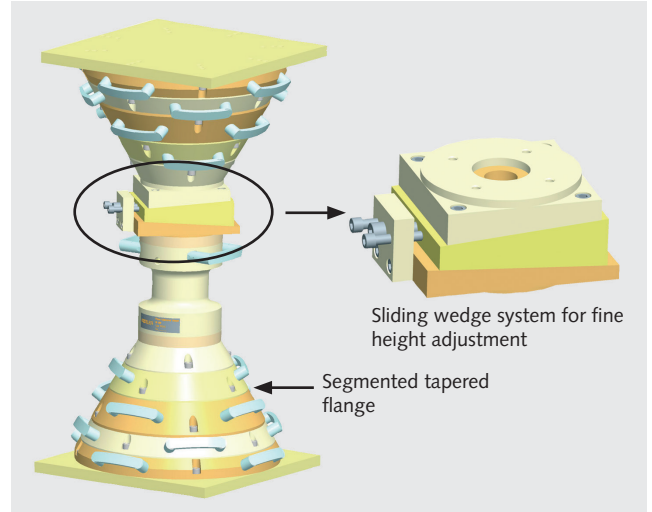

Fig. 13: Example of a solution with Type 9931A4 as well as a sliding wedge system and segmented tapered flange

Ordering Key

Measuring range

F _z = 2 500 kN	1
F _z = 5 000 kN	2
F _z = 10 000 kN	3
F _z = 20 000 kN	4

Type 9931A □



9931A_000-525e-08.18



Fig. 12: Type 9588A3x tapered flange