

Upper Neck Load Cell

Six-axial

Type M555A6A...,
M555A6C...

Type M555A6... is designed to measure forces and moments in the upper neck of the crash test dummies HIII-5 % (HF), HIII-50 % (H3), HIII-95 % (HM), HIII-3 year old (Y6) and SID-IIs (S2).

- Six-axial (F_x , F_y , F_z , M_x , M_y , M_z)
- ID module available
- Low linearity errors and hysteresis errors
- Kistler system cabling
- Polarities according to SAE J211/1

Description

The load cell is made of elements on which forces are transmitted. The mechanical deformation element, applied with strain gage, serves for mechanical electrical deformation. The effectiveness of the load cell resembles the behavior of a spiral spring. The forces to be measured create mechanical stretches and buckling in the gaging member. In order to avoid linearity errors, the deformation paths are constructively held small (high rigidity).



Thus a proportional behavior is realized. The force and moment proportional resistance variations are measured by a Wheatstone-type bridge circuit. The load cell is available with ID module which is integrated in an external housing in the wiring or in the connector. Customized cable lengths and connectors with specific pin assignments are optionally available.

Technical Data

Axial Data		F_x	F_y	F_z	M_x	M_y	M_z
Measuring range	kN	9	9	13			
	N·m				280	280	280
Bridge output voltage (typ.)	mV/V	1,6	1,6	1,2	1,6	1,6	2,3
Sensitivity (typ.)	$\mu\text{V}/\text{V}/\text{kN}$	180	180	90			
	$\mu\text{V}/\text{V}/\text{N}\cdot\text{m}$				6	6	8
Bridge resistance	Ω	700 ¹⁾	700 ¹⁾	700	350	350	350 ¹⁾
Ultimate load, static	%	150	150	150	150	150	150

General Data

Supply voltage ²⁾	VDC	2,5 ... 15
Insulation resistance ³⁾	G Ω	>10
Operating temperature range	$^{\circ}\text{C}$	-20 ... 80
Storage temperature range	$^{\circ}\text{C}$	-30 ... 90
Amplitude non-linearity (typ.)	%	<1
Hysteresis (typ.)	%	<1
Channel cross talk	%	<5
Bridge zero output (typ. / max.)	mV/V	0,01 / 0,03
Weight, without cable	grams	640

All specifications are typical at 25 $^{\circ}\text{C}$ and rated at 10 V sensor supply voltage, unless otherwise specified.

¹⁾ Up to serial number 0004677629 (up to year of construction 2015) the bridge resistance of the load cells is 350 Ω (F_x , F_y) resp. 700 Ω (M_z). Please mind the first calibration!

²⁾ With UPS module 9 ... 12 VDC

³⁾ All wires to load cell housing, measured with 500 VDC

Application

The load cell is directly assembled at the designated location in the dummy and provides important information about the loads on the human body occurring during a crash test.

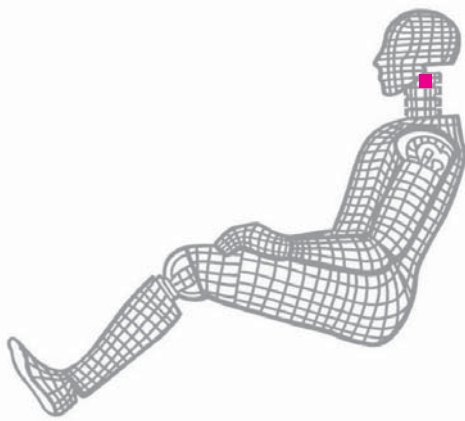

Fig. 1: Dummy application, location upper neck

Included Accessories

- Calibration adapter
- Mounting screws, imperial 1/4-28 UNFx7/8 (DIN 912)

Art. No.

on request
on request

Optional Accessories

- ID module

Art. No.

on request

Ordering Key

Type M555A6

Standard	AFM
With MIKQ socket	CFM

Cable Length before Electronics

0 cm	00
<10 cm (digit x 1 cm)	C#
10 cm ... 9,9 m (digit x 10 cm)	##
10 m ... 90 m (digit x 10 m)	D#

Additional Electronics

Sensor detail, as per type declaration force-moment TP-650-2	#
--	---

Cable Length after Electronics

0 cm	00
<10 cm (digit x 1 cm)	C#
10 cm ... 9,9 m (digit x 10 cm)	##
10 m ... 90 m (digit x 10 m)	D#

Connector

Conn. type, as per TP-600	#-
Conn. assignment, as per TP-600	-#

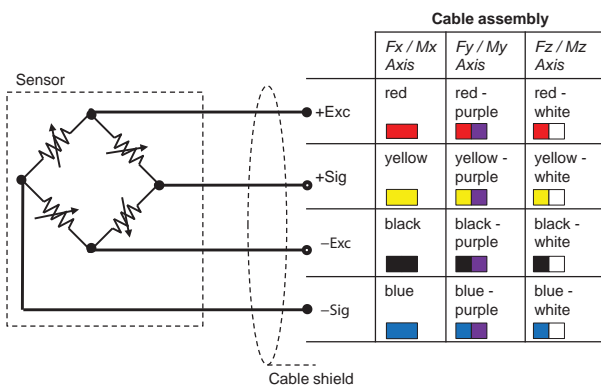

Fig. 2: Cable connection

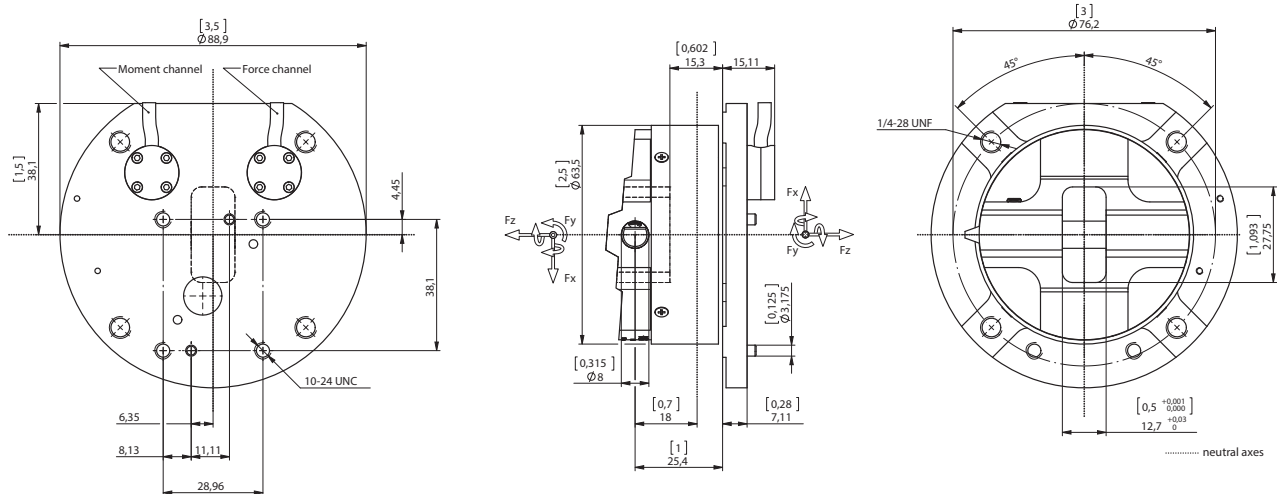

Fig. 3: Dimensions

M555A6_000-790e-03.16