

Multichannel Charge Amplifier

for Multicomponent Force Measurement

Type 5070A...

This instrument is ideal for multicomponent force-torque measurement with piezoelectric dynamometers or force plates. Piezoelectric force sensors produce an electric charge which varies in direct proportion with the load acting on the sensor. The charge amplifier then converts the electric charge into a proportional voltage.

- 4-channel version for cutting force measurements
- 8-channel version for multicomponent force-torque measurement
- 8-channel version optionally with 6-component analog summing calculator
- Menu-controlled operation as with Type 5015A...
- Direct signal evaluation
- Suitable for data acquisition software DynoWare Type 2825A-02

Description

Type 5070A... is available as a 4-channel or 8-channel version. As an option, the 8-channel version can also be provided with a 6-component analog summing calculator. In the case of Kistler multicomponent dynamometers, this summing calculator calculates in real time mode the resulting force as well as the three components of the resulting torque vector. Dynamometer-specific values required for torque calculation can be set directly on the instrument.

The graphics-capable liquid crystal display shows all settings including the instantaneous, minimum and maximum values of a charge amplifier channel. The various channels can be switched onto the display as required. The instrument is set up by means of various menus with the universal press-and-turn knob. All functions can, however, also be controlled externally via RS-232C (optionally IEEE-488).

Application

The 4-channel instrument is particularly suitable for cutting force measurement with Kistler dynamometers and the data acquisition software DynoWare Type 2825A-02. The 8-channel instrument is suitable for 6-component force-torque measurement in the laboratory as well as in research and development. For example, wheel force measurement on a tire test stand, reaction force measurements on engine-transmission units, monitoring of forces and torques in vibration tests etc.



Technical Data

Charge Amplifier

Number of channels		4
Option		8
Connector type		BNC neg.
Option		Fischer 9-pole neg.
Measuring range FS	pC	±200 ... 200 000
Option	pC	±600 ... 600 000
Measurement uncertainty (0 ... 50 °C) typ./max.	%	<±0,3/<±1
Drift, measuring mode DC (Long) at 25 °C, max. relative humidity RH of 60 % (non-condensing)	pC/s	<±0,05 (typ. <±0,03)
at 25 °C, max. relative humidity RH of 70 % (non-condensing)	pC/s	typ. <±0,05
at 50 °C, max. relative humidity RH of 50 % (non-condensing)	pC/s	<±0,2
Frequency range (20 Vpp)	kHz	≈0 ... >45
Group delay	µs	<9

Voltage Output

Connector type		D-Sub 15f
Output voltage	V	±10
Output current	mA	<±2
Output resistance	Ω	10
Reset-measure transition	pC	<±2
Zero point error (Reset)	mV	<±10
Output interference signal (0,1 Hz ... 1 MHz)	mVpp	<10

Page 1/8

This information corresponds to the current state of knowledge. Kistler reserves the right to make technical changes. Liability for consequential damage resulting from the use of Kistler products is excluded.

©2010 ... 2016, Kistler Group, Eulachstrasse 22, 8408 Winterthur, Switzerland
 Tel. +41 52 224 11 11, Fax +41 52 224 14 14, info@kistler.com, www.kistler.com
 Kistler is a registered trademark of Kistler Holding AG.

Low-Pass Filter

Order		2
Cutoff frequency (-3 dB)	Hz	100, 300, 600, 1 000, 2 000
Error	%	<±5

High-Pass Filter

Zero point error	mV	<±15
Time constant		
Range 200 ... 200 000 pC		
200 ... 6 269 pC	s	10
6 270 ... 200 000 pC	s	340
Time constant		
Range 600 ... 600 000 pC		
600 ... 18 809 pC	s	33
18 810 ... 600 000 pC	s	1 023
Error (time constant)	%	<±20

Signal Evaluation

Measurand renewal		
Instantaneous value	ms	300
Minimal value	ms	300
Maximal value	ms	300
Bar display	ms	50

Summing Calculator (Option)

Specifications are valid incl. charge amplifier

Number of summation outputs		6
Measurement uncertainty		
(0 ... 50 °C) typ./max.	%	<±0,5/<±1
Output voltage	V	±10
Output current (short-circuit proof)	mA	±2
Output resistance	Ω	10
Zero point error (Reset)	mV	<±10
Output interference signal		
(0,1 Hz ... 1 MHz)	mVpp	<10
Frequency range (20 Vpp)	kHz	≈0 ... >45

RS-232C Interface

Standard		RS-232C (V.24)
Connector type		D-Sub 9f
Pin allocation		
Pin 2		R X D
Pin 3		T X D
Pin 5		GND RS
Max. input voltage, continuous	V	±20
Max. voltage between signal ground and protective ground	V _{RMS}	<20
Baud Rates		1 200/9 600/ 19 200/ 38 400/ 57 600/115 200
Data bit		8
Stop bit		1
Parity		none

IEEE-488 Interface (Option)

Standard		IEEE-488.1-1987
Connector type		Microribbon Series 57, (24-pole)
Interface functions		SH1, AH1, L4, LEO, T6, TE0, SR1, RL2, PP0, DC1, DT1, C0, E1
Uniline commands		IFC, REN, EOI, SRQ, ATN
Multiline commands		DCL, SDC, GET, UNL, UNT, SPE, SPD
Adress range		0 ... 30

Remote Control

(Digital input and 24 V supply)

Remote measure and trigger with 10 kΩ pullup to +5 V

Connector type		D-Sub 9f
Input level		
High (Reset, Stop trigger)	V	>3,5
or		Input open
Low (Measure, Start trigger)	V/mA	<1/<4
Max. input voltage	V	±30
Supply (output)	V DC	+24/±20 %
Output current (short-circuit proof)	mA	<200

Mains Connection

Mains connector type		
(2P + E, Protective class I)	Type	IEC 320C14
Voltage	VAC	100 ... 240
Voltage tolerance	%	±10
Mains frequency	Hz	50 ... 60
Power consumption	VA	20
Voltage between signal ground and protective ground	V _{RMS}	<50

Further Technical Data

Degree of protection		
IEC60529 (DIN40050)	IP	40
Operating temperature	°C	0 ... 50
Storage temperature	°C	-10 ... 60
Relative air humidity non-condensing	%	<80
Vibration resistance (20 Hz ... 2 kHz, duration 16 Min., cycle 2 Min.)	g	<10
Shock resistance (1 ms)	g	<200
Case dimensions		
without frame (BxHxT)	mm	213,4x128,7x230
with frame (BxHxT) (Option)	mm	247,5x142x253,15
Front panel according to		
DIN 41494, Part 5	HE/TE	3/42
Weight	kg	3,8

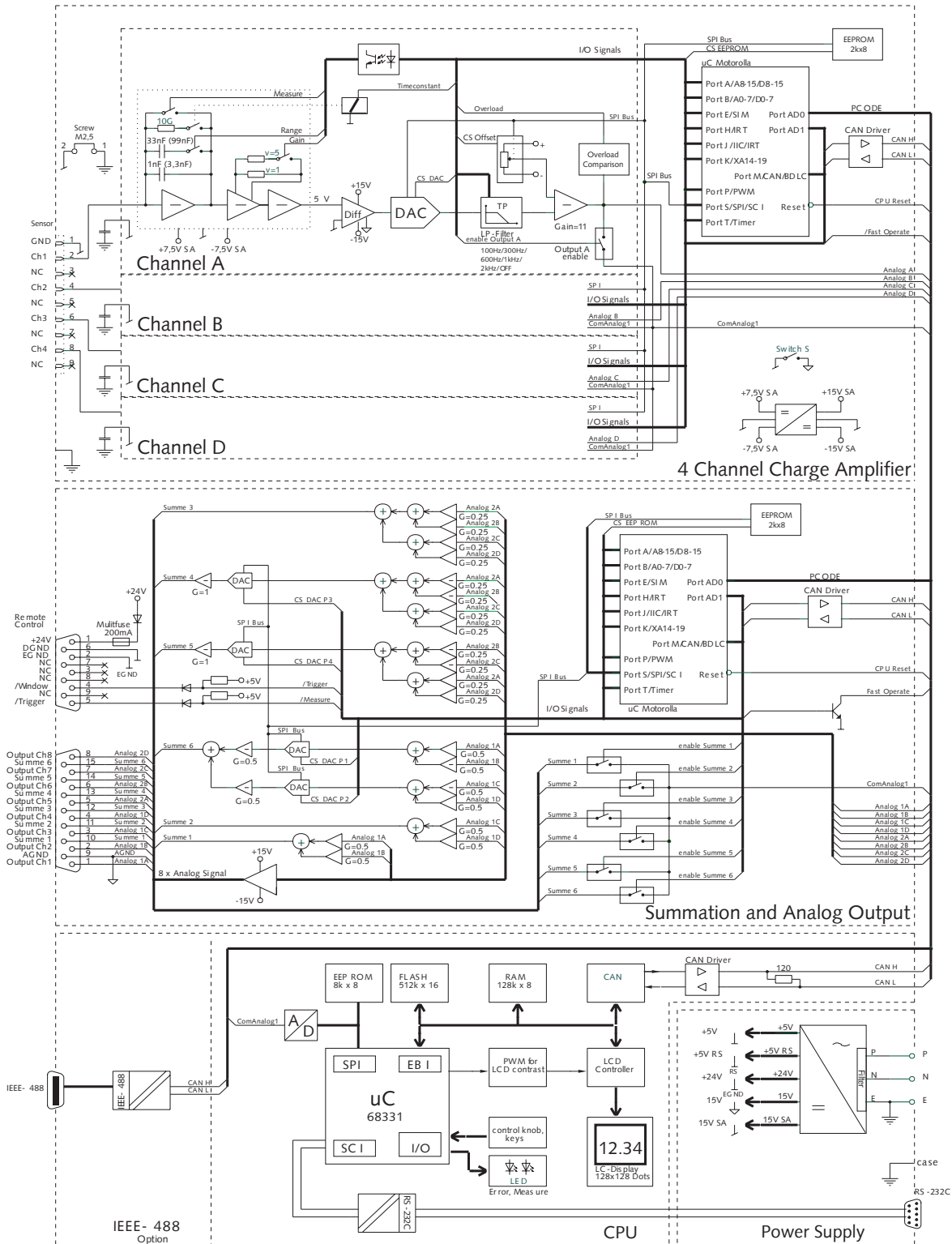

5070A_000-485e-07.16

Fig. 1: Block schematic diagram Type 5070A...

3-Component Force Measurement F_x, F_y, F_z with 4-Channel Charge Amplifier

Dynamometer
Type 9119AAx, 9129A, 9129AA, 9253B,
9255C, 9257B, 9139AA

Cable

Charge Amplifier
Type 5070Ax01xx

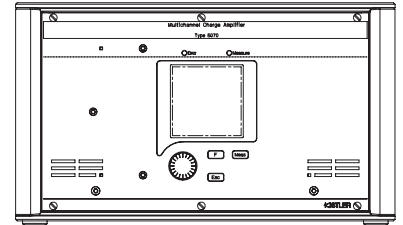
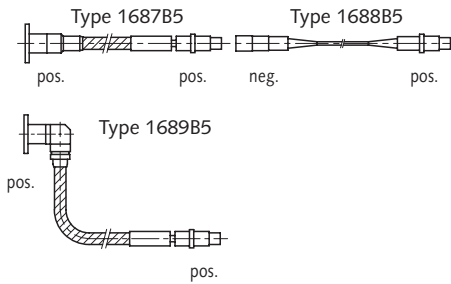
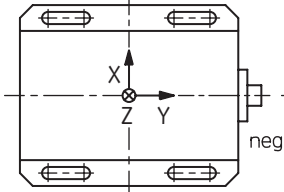

3 output signals
from the charge amplifier

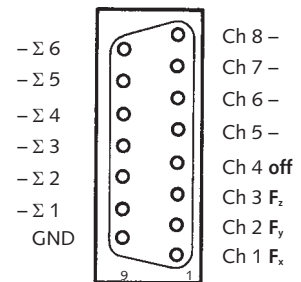

Fig. 2: Example of a measuring system with standard dynamometer

Measured Value Processing

DynoWare Type 2825A... is suitable for data acquisition.

4-Component Force-Torque Measurement M_z, F_z, F_y, F_x with 4-Channel Charge Amplifier

Dynamometer
Type 9272

Cable

Charge Amplifier
Type 5070Ax01xx

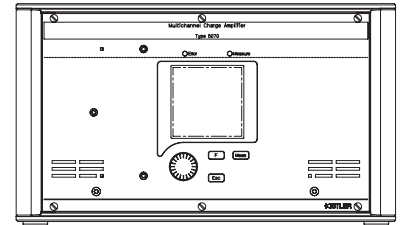
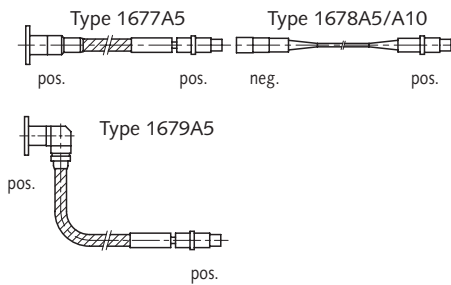
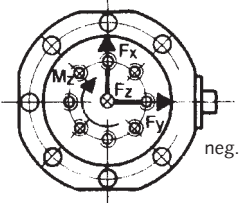

4 output signals
from the charge amplifier

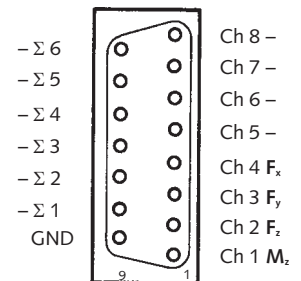

Fig. 3: Example of a measuring system with dynamometer Type 9272

Measured Value Processing

DynoWare Type 2825A... is suitable for data acquisition.

5070A_000-485e-07.16

6-Component Force-Torque Measurement F_{x1} , F_{y1} , F_{z1} , M_{x1} , M_{y1} , M_{z1} with 8-Channel Charge Amplifier

Dynamometer
Type 9119AAx, 9129AA, 9253B,
9255C, 9257B, 9139AA

Cable

Charge Amplifier
Type 5070Ax11xx

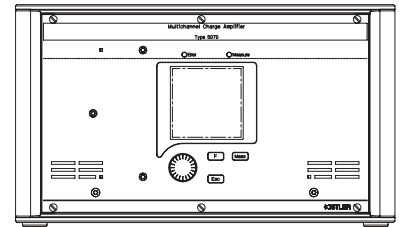
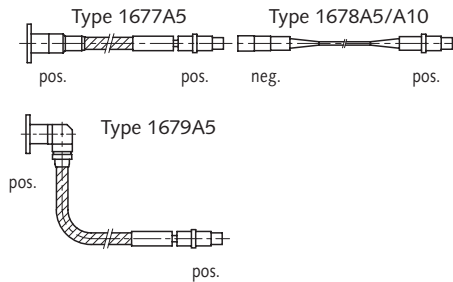
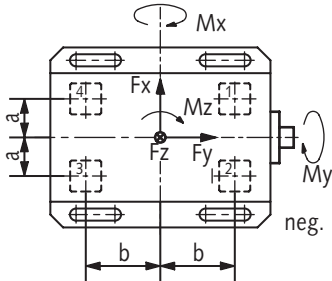

8 output signals
from the charge amplifier

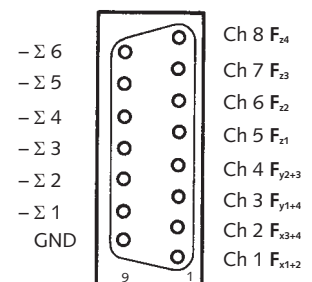

Fig. 4: Example of a measuring system with standard dynamometer

Measured Value Processing

The six components F_x , F_y , F_z , M_x , M_y , M_z must be calculated from the eight output signals from the charge amplifier. The data acquisition software DynoWare Type 2825A... is ideal for this purpose.

Formulae for Calculations

$$F_x = F_{x1+2} + F_{x3+4}$$

$$F_y = F_{y1+4} + F_{y2+3}$$

$$F_z = F_{z1} + F_{z2} + F_{z3} + F_{z4}$$

$$M_x = [b \cdot (F_{z1} + F_{z2} - F_{z3} - F_{z4})] \text{ kM}_x$$

$$M_y = [a \cdot (-F_{z1} + F_{z2} + F_{z3} - F_{z4})] \text{ kM}_y$$

$$M_z = [b \cdot (-F_{x1+2} + F_{x3+4}) + a \cdot (F_{y1+4} - F_{y2+3})] \text{ kM}_z$$

- a = Distance of the sensor axis from the y-axis
- b = Distance of the sensor axis from the x-axis
- kM_x , kM_y , kM_z = Correction factor of torque calibration (special calibration required)

Values a, b from Standard Dynamometers

Type	a mm	b mm
9119AA1	28,5	24,5
9119AA2	28,5	32,5
9129AA	33	50,5
9253B	120	200
9255C	80	80
9257B	30	57,5
9139AA	60	78,5

5070A_000-485e-07.16

6-Component Force and Torque Measurement $F_x, F_y, F_z, M_x, M_y, M_z$ with 8-Channel Charge Amplifier with 6-Component Summing Calculator

Dynamometer
Type 9119AAx, 9129AA, 9253B, 9255C,
9257B, 9139AA

Cable

Charge Amplifier
Type 5070Ax21xx

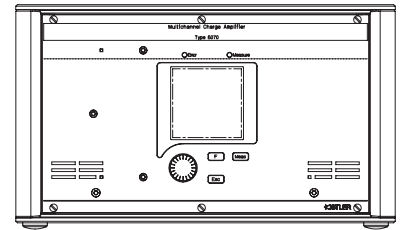
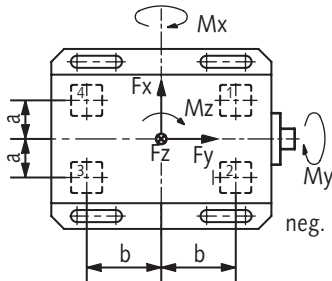

8 output signals from the charge amplifier
6 output signals from the summing calculator

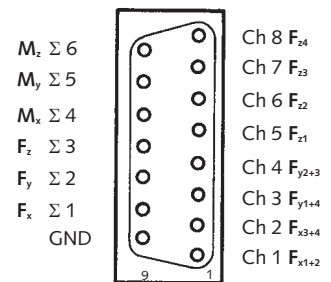

Fig. 5: Example of a measuring system with standard dynamometer

Measured Value Processing

The analog summing calculator calculates $F_x, F_y, F_z, M_x, M_y, M_z$ in real time mode. DynoWare Type 2825A is ideal for the data acquisition.

However, DynoWare can also be used to calculate the six components from the eight output signals from the charge amplifier (see page 6).

Measured Value Processing Type 5070Ax21xx

- a = Distance of the sensor axis from the y-axis
- b = Distance of the sensor axis from the x-axis
- kM_x, kM_y, kM_z = Correction factor of torque calibration (special calibration required)

Values a, b from Standard Dynamometer

Type	a mm	b mm
9119AA1	28,5	24,5
9119AA2	28,5	32,5
9129AA	33	50,5
9253B	120	200
9255C	80	80
9257B	30	57,5
9139AA	60	78,5

5070A_000-485e-07.16

5-/(6-)Component Force and Torque Measurement F_{x1} , F_{y1} , F_{z1} , M_{x1} , (M_{y1}), M_{z1} with 8-Channel Charge Amplifier with 6-Component Summing Calculator

RoadDyn Measuring Hub
Type 9295...

Cable

Charge Amplifier
Type 5070Ax211x

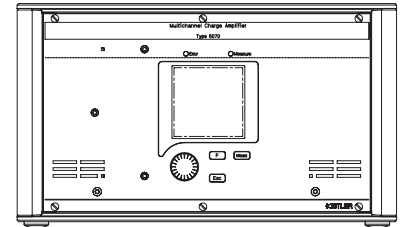
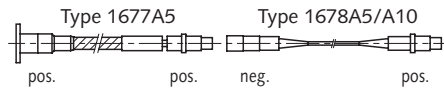
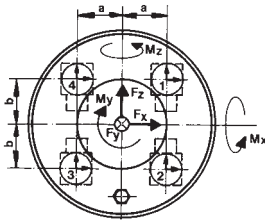

8 output signals from the charge amplifier
6 output signals from the summing calculator

Fig. 6: Example of a measuring system with RoadDyn measuring hub Type 9295...

Measured Value Processing

The analog summing calculator calculates the five (six) components F_{x1} , F_{y1} , F_{z1} , M_{x1} , (M_{y1}), M_{z1} in real time mode.

Formulae for Calculations

$$F_x = F_{x1+4} + F_{x2+3}$$

$$F_z = F_{z1+2} + F_{z3+4}$$

$$F_y = F_{y1} + F_{y2} + F_{y3} + F_{y4}$$

$$M_z = [a \cdot (F_{y1} + F_{y2} - F_{y3} - F_{y4})] \cdot kM_z$$

$$M_x = [b \cdot (-F_{y1} + F_{y2} + F_{y3} - F_{y4})] \cdot kM_x$$

$$(M_y) = -[b \cdot (-F_{x1+4} + F_{x2+3}) + a \cdot (F_{z1+2} - F_{z3+4})] \cdot kM_y$$

Input Values for Type 5070Ax211x

- a = Distance of the sensor axis from the y-axis
- b = Distance of the sensor axis from the x-axis
- kM_x , kM_z , (kM_y) = Correction factor of torque calibration (special calibration required)

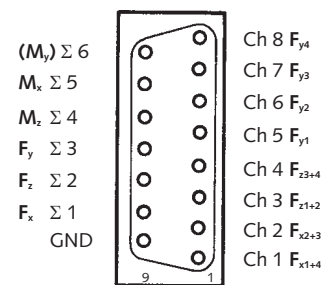

Values a, b from Dynamometer

Type	a mm	b mm
9295...	80	80

5070A_000-485e-07.16



Fig 7: Rear panel Type 5070A1x10



Fig 8: Multichannel charge amplifier in 19" cassette with panel mounting set Type 5070A2xxxx

Accessories Included

- Country-specific mains cable
- Flash loader with relevant firmware
- Instruction manual
- Calibration certificate

Optional Accessories

- RS-232C interface cable
- Inductive proximity switch generates an external trigger signal to start measurement DynoWare 2825A-02

Type
1200A27
2233B

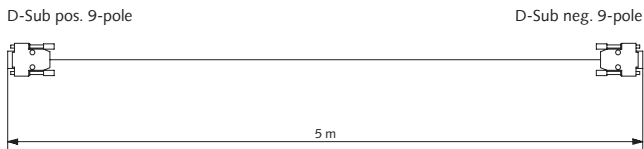

Fig. 9: RS-232C interface cable Type 1200A27

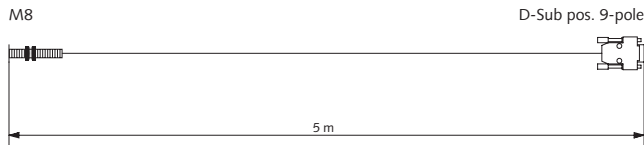

Fig. 10: Inductive proximity switch Type 2233B

Ordering Key

Type 5070A

Case

19" cassette for rack mounting	0
Desk top version with support bracket	1
19" cassette version with panel mounting set	2

Number of Channels

4 channels	0
8 channels	1
8 channels with 6-component summing calculator	2

Measuring Signal Input

BNC neg.	0
Fischer 9-pole neg.	1

Measuring Range

±200 ... 200 000 pC	0
±600 ... 600 000 pC	1

Interface

RS-232C	0
RS-232C and IEEE-488	1

Ordering Example Type 5070A10100

(suitable for cutting force measurement)

Multichannel Charge Amplifier for Multicomponent Force Measurement

Case: Desktop unit with mounting bracket
 Number of channels: 4
 Measuring signal input: Fischer 9-pole neg.
 Measuring range: ±200 ... 200 000 pC
 Interface: RS-232C