

K-Shear[®] Accelerometers

Type 8838/8840

Axial/Lateral Rotational Accelerometers

Uniquely configured shear-quartz sensing elements that enable Type 8838 axial accelerometer to measure oscillations occurring about the mounting bolt axis and allow Type 8840 lateral accelerometer to measure oscillations occurring about a centerline axis passing through the electrical connector.

- Shear quartz piezoelectric principle
- Axial or lateral oscillations
- Hermetic construction
- Lightweight and convenient thru hole mount
- Conforming to CE



Description

Types 8838 and 8840 are novel complements of shear mode sensors that are designed to respond to two distinctly different forms of induced oscillations. The internal orientation of the quartz elements enables Type 8838 accelerometer to respond to oscillations occurring about the unit's mounting axis when installed in a non-rotating test application. The element structure of Type 8840 accelerometer is such that the unit will accurately measure the acceleration magnitude of oscillations laterally induced to its mounting base.

Kistler's shear technology assures high immunity to base strain, thermal transients and transverse accelerations. Notable features include wide frequency response, lightweight titanium construction, hermetic, and ground isolated design. Included within both models are signal processing electronics that convert the charge generated by the mechanical system into a high voltage signal level at a low impedance output. These accelerometers do not use standard voltage mode piezoelectric sensor couplers but are powered by any commercially available (20 to 30 VDC) power supply.

Application

- Axial or shaft type measurements on an oscillating but non-rotating specimen
- Active control of positioning systems; performance and compensation
- Frontal or lateral rotations encountered by instrumented crash test dummies

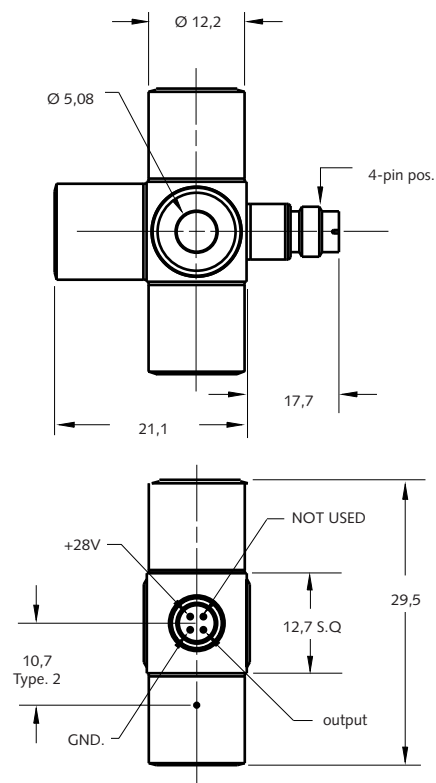

8838_000-271e-07.09

Technical Data

Specification	Unit	Type 8838/8840
Acceleration range	krad/s ²	±150
Acceleration limit	krad/s ²	±200
Threshold (noise 130 µVrms)	rad/s ²	4
Sensitivity nom.	µV/rad/s ²	35
Resonant frequency mounted, nom.	kHz	23
Frequency response, ±10%	Hz	1 ... 2000
Amplitude non-linearity	%FSO	1
Time constant	s	1
Transverse sensitivity typ. (max.)	%	1,5 (2)
Vibration max.	g	2000
Shock limit (1ms pulse width) max.	g	5000
Base strain sensitivity @250µε	g/µε	0,005
Long term stability	%	±1
Temperature coefficient of sensitivity	%/°C	-0,06
Temperature range operating	°C	-55 ... 120
Temperature range storage	°C	-75 ... 150

Output

Voltage FS nom.	V	±5
Current	mA	2
Impedance	Ω	<100

Source

Voltage	VDC	20 ... 30
Current	mA	4

Construction

Sealing-housing/connector	Type	hermetic
Housing/base	material	titanium
Sensing element	Type	quartz/shear
Connector	Type	4-pin pos.
Weight	grams	18,5
Ground isolation min.	MΩ	10
Mounting	Type	cap screw
Mounting torque	Nm	2

1 g = 9,80665 m/s², 1 Inch = 25,4 mm, 1 Gramm = 0,03527 oz, 1 lbf-in = 0,113 Nm

Mounting

Reliable and accurate measurements require a clean and flat mounting surface. The sensor can be attached to the structure by a single 10-32 socket head cap screw. The operating instruction manual for Types 8838/8840 provides detailed information regarding mounting surface preparation.

Accessories Included

- Socket head cap screw, 10-32 x 0.75" long 431-0475-003
- Socket head cap screw, M5 x 20 mm long 431-0494-001

Optional Accessories

- 4-pin Microtech neg to 1786C...
(2x) banana jacks, BNC pos

Ordering Key

Measuring range	Type 88
±150 krad/s ² axial acceleration	38
±150 krad/s ² lateral acceleration	40