

# Piezoresistive high pressure sensor for measurements at gas and hydraulic systems

Type 4065B...DS

Compact high pressure sensor with robust diaphragm for measurements at hydraulic systems (e.g. injection systems of combustion engines). Suitable for static and dynamic pressure.

- For measuring static and dynamic pressure
- Minimal sensor dead volume, therefore high acoustic natural frequency
- High mechanical natural frequency
- Digital temperature compensation

### Description

In Type 4065B...DS, the pressure acts through a robust diaphragm onto a piezoresistive measuring element. The compact dimensions and the shoulder sealing of the sensor provide ideal access to the measuring point. Only a minimal dead volume is created between the sensor front and the measured medium. The sensor is therefore suitable for applications with a high requirement for frequency-accurate pressure measurements.

Zero point and sensitivity shift caused by temperature changes are corrected through the use of a digital temperature compensation without impairing the signal bandwidth. In addition, the digital temperature compensation provides a monitoring of the sensor temperature (amplifier Type 4665B... and Type 4624A...).

### Application

The sensor Type 4065B...DS is used in applications where average to high pressures must be measured with a static and a dynamic component. Examples include:

- General pressure measurements in gas and hydraulic systems
- Frequency-accurate analysis of pressure curves in gasoline or diesel injection pressure systems

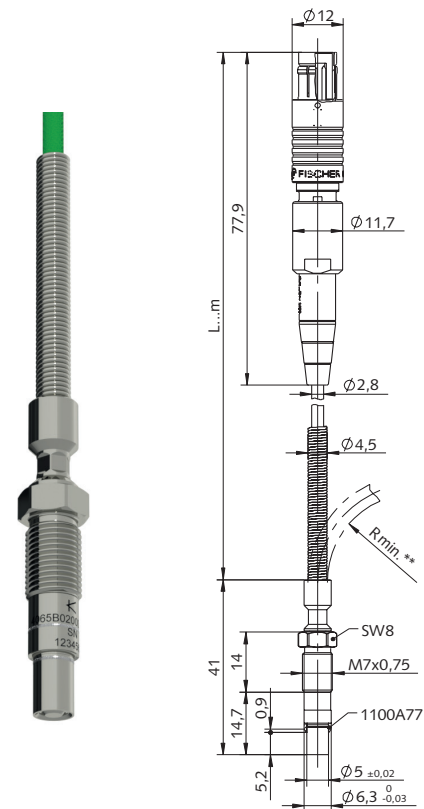

\*\* Rmin. 20 fixed installation  
Rmin. 41 free movement

### Technical Data

Measuring range	bar	0 ... 200, 0 ... 500, 0 ... 1 000
Overload	bar	300, 750, 1 000
Electrical connection		Fischer connector 5 pole (S103A054)
Amplifier compatibility	Type	4665, 4665B, 4624A
Power supply		amplifier integrated
Reference temperature (Tref)	°C	25
Sensor temperature, min./max.	°C	-40/140
Temperature compensation		digital
Temperature compensation range	°C	25 ... 120
Max. deviation pressure*	%FSO	≤±1,5
Max. deviation temperature*	°C	≤±3
Linearity at Tref (LSQ)	%FSO	≤±0,3
Natural frequency 200, 500 bar	kHz	>40
1 000 bar	kHz	>100

4065B\_003-165e-04\_19

## Technical Data (Continuation)

Acceleration sensitivity	mbar/g	≤10
Life cycle (typical)	load change	>10 <sup>7</sup>
Mounting torque sensor	N·m	5
Weight (without connector and cable)	g	9
Protective class		IP65

\* Measuring results based on digital compensation with DS-compatible amplifier. The deviations include measuring errors due to sensor characteristics (linearity, hysteresis, thermal effects) and a compensation model.

## Installation

The sensor can be mounted directly in a mounting bore (fig. 1) or by using (clamp) adapters (fig. 2, fig. 3). Clamp adapters are available for various diameters of injection lines.

## Mounting

Using the correct drill dimensions and tolerances is extremely important when machining the mounting bores. The sealing surface must be clean and free of metal particular to guarantee leak tightness.

The pressure sensor is always installed together with a cone-shaped metallic sealing (Type 1100A77). Following the recommended tightening torque is mandatory when tightening the pressure sensor. Therefore, the sensor must be mounted using a suitable fork wrench (e.g. Type 1300A29, figure 7) and the torque wrench (Type 1300A11, figure 8).

The zero point may shift slightly after the installation due to the sensor's sensitivity to tightening torques. Therefore, a zero point correction is recommended. For the Kistler amplifiers Type 4665B... and 4624A..., this functionality is provided at the amplifier itself or in the software.

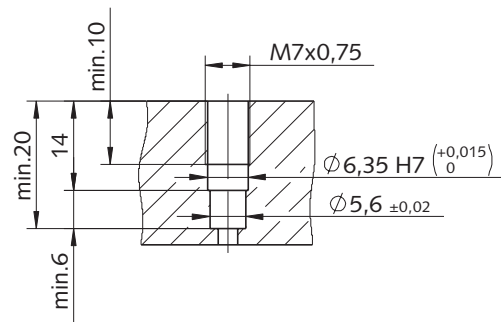

Fig. 1: Mounting bore for direct mounting

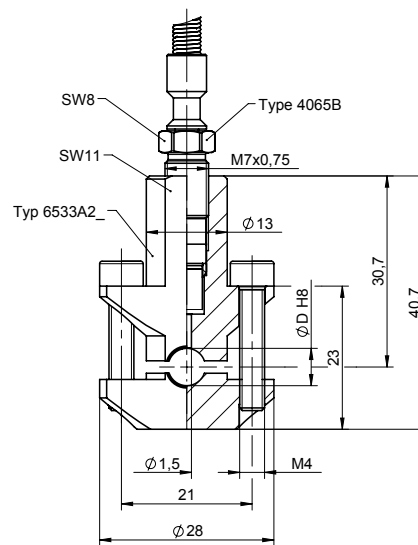

Fig. 2: Installation in clamp adapter Type 6533A2... (D6,0 with Type 6533A21, D6,35 with Type 6533A22, D6...8 with Type 6533A28)

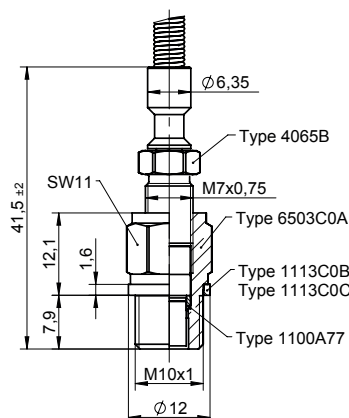

Fig. 3: Installation in adapter Type 6503C0A

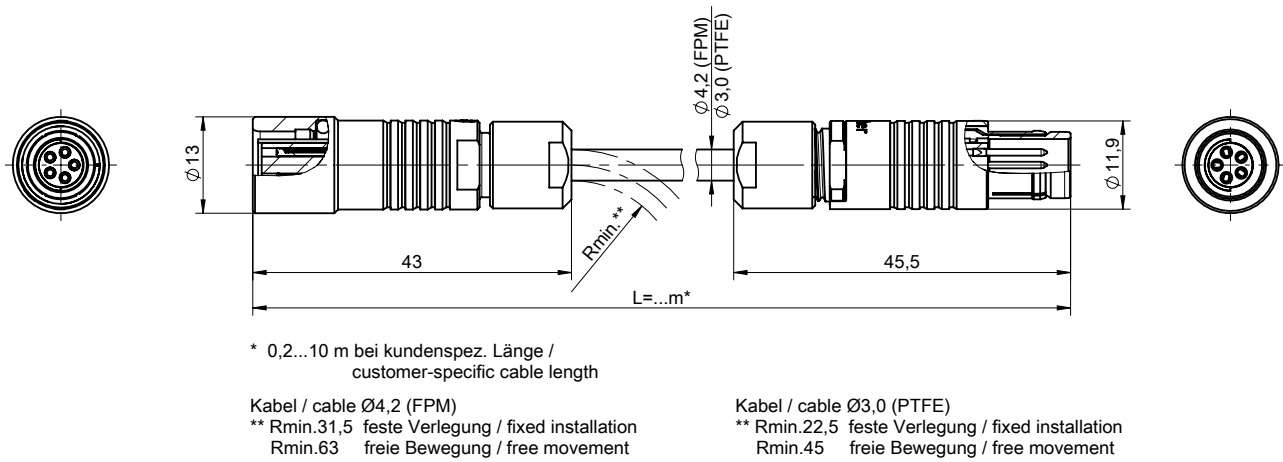

Fig. 4: Extension cable Type 4785A\_1

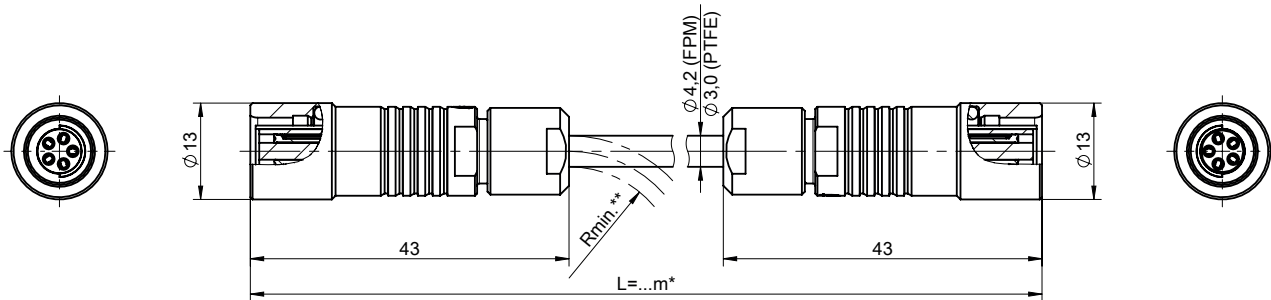

Fig. 5: Adapter cable Type 4785A\_2 for an easy connection of DS sensors to existing wiring with Type 4761B...

**Included accessories**

- Seals (2 units)

**Type**  
1100A77

**Accessories (optional)**

- Step drill 1331
- Screw tap M7x0,75 1351
- Mounting key for deep bores 1300A41
- Torque wrench  
4 ... 20 N·m 1300A39  
8 ... 40 N·m 1300A11
- Fork wrench for Type 1300A39 or Type 1300A11, SW8 1300A29
- Fork wrench for Type 1300A39 or Type 1300A11, SW11 1300A75

**Adapter**

- Blind sensor 6447
- Clamp adapter for 6 mm pipe 6533A21
- Clamp adapter for 6,35 mm pipe (6,35 mm = 1/4") 6533A22
- Clamp adapter 6 ... 8 mm pipe 6533A28
- Clamp adapter 8 ... 13 mm pipe 6533A29

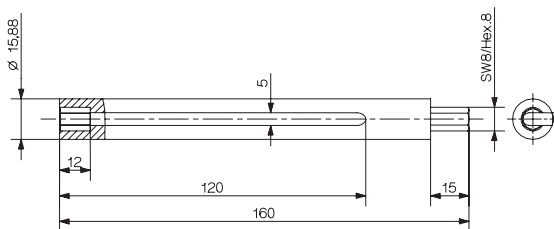

Fig. 6: Mounting key for deep bores Type 1300A41

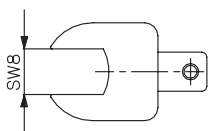

Fig. 7: Fork wrench Type 1300A29

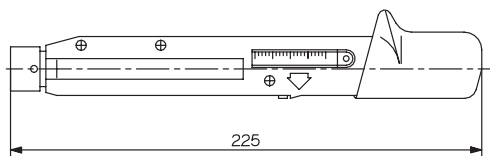

Fig. 8: Torque wrench Types 1300A11 and 1300A39

- Adapter M14x1,25 4155
- Adapter M10x1 6503C0A

**Amplifier/SCP**

- SCP (slim-) for 2 meas. modules 2852A...
- SCP for 8 meas. modules 2853A...
- Piezoresistive SCP amplifier 4665B...
- Piezoresistive 1 channel amplifier 4624A...
- Extension cable for sensor FPM (0 ... 180 °C)
  - L = 1 m 4785A41-1,00
  - L = 2 m 4785A41-2,00
  - L = 3 m 4785A41-3,00
  - L = 5 m 4785A41-5,00
  - L = 7,5 m 4785A41-7,50
  - L = 10 m 4785A41-10,0
  - L = ...m (L<sub>min</sub> = 0,5/L<sub>max</sub> = 10 m) 4785A41-SP-...
- Extension cable for sensor PTFE (-40 ... 180 °C)
  - L = ... m (L<sub>min</sub> = 0,5/L<sub>max</sub> = 10m) 4785A11-SP-...
- Adapter cable for connection of DS sensor to 4761B... cable 4785A42...

**Ordering Key**Type 4065B  DS  - **Pressure Range**

0 ... 200 bar	0200
0 ... 500 bar	0500
0 ... 1 000 bar	1000

**Sensor Type**

Digital compensation and PiezoSmart®	DS
--------------------------------------	----

**Cable Type**

PTFE cable	1
------------	---

**Cable Length**

2 m	2,0
-----	-----

**Ordering example: Type 4065B0200DS1-2,0**

- Version with measuring range 200 bar, with digital compensation and PiezoSmart®, cable length 2 m. Compatible with Kistler amplifier Types 4665, 4665B... and 4624A... .