

# Piezoresistive High Pressure Sensor

Type 4067C3000...

## with Amplifier

High pressure sensor with rugged diaphragm and front seal for measuring on hydraulic Systems, (eg. fuel injection Systems of internal combustion engines), and gas pressure measurements. Suitable for static and dynamic pressures. Its small dimensions allow its use with a clamp adapter on the injection pipe.

- Measuring range up to 3 000 bar
- Measures static and dynamic pressures
- High natural frequency
- This is one of the smallest sensors for static measurement

### Description

The pressure to be measured acts through a rugged diaphragm on an arrangement of piezoresistive "rods". The pressure changes the values of the resistances diffused into the rods. These resistances are arranged in a Wheatstone bridge.

The pressure sensor itself is not temperature compensated. The amplifier Type 4618A... provides temperature compensation, linearisation of the pressure signal and contains a stabilized power supply. For this reason, the sensor must always be operated with the amplifier adjusted to it.

Amplifier Type 4618A... additionally contains two adjustable limit switches with optocouplers. A version with simultaneous temperature measurement is available as an option.

### Application

Sensor Type 4067C3000... is used appropriately wherever high pressures with a static component have to be measured in confined spaces. Examples are the fine tuning of injection systems in diesel engines or measurements on hydraulic systems.

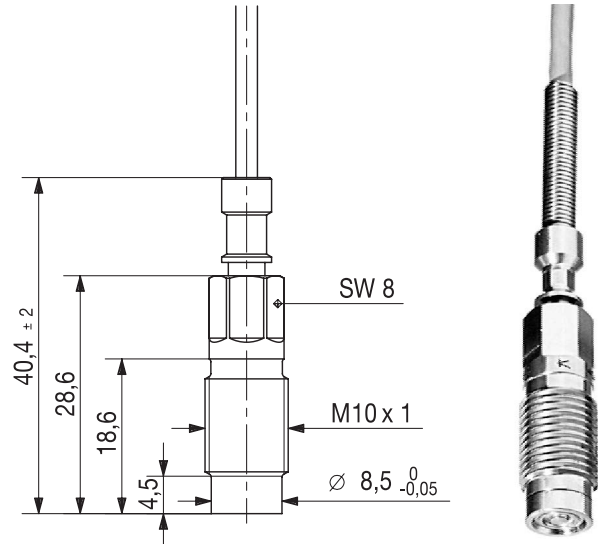

### Mounting

The device can be mounted directly (Fig. 4) or with the aid of a clamp adapter (Fig. 6) available for different diameters of injection lines.

The sealing joint Type 1100 (Fig. 5) supplied provides good leak-tightness even at high static pressures and small tightening torques.

Tightening must be carried out with a torque wrench. The permissible tightening torque must on no account be exceeded, otherwise the sensor will be damaged beyond repair. In the event of a leakage, the sealing joint Type 1100 should be exchanged and the contact surface re-machined with end finishing tool Type 1300A25. The sensor zero is sensitive to tightening. If the zero point is displaced, it can be corrected at the amplifier with an externally accessible potentiometer.

4067C\_000-708e-08.08

## Technical Data

### Type 4067C3000...

Range	bar	0 ... 3 000
Overload	bar	3 500
Sensitivity	mV/bar	3,333
(±0,5 % at 25 °C)		
Natural frequency	kHz	>200
Output signal	Depends on measuring chain <sup>1)</sup>	
Output Impedance	Ω	10
Supply (amplifier)	V DC	18 ... 30
Zero (at 25 °C, 1 bar abs)	mV	<±100*
Endpoint linearity	% FSO	<±0,5
Thermal zero shift	% FSO	<±1
Thermal sensitivity shift	%	<±1
Operating temperature range		
Sensor	°C	20 ... 120
Amplifier Type 4618Ax	°C	0 ... 70
Storage temperature	°C	-40 ... 140
Operating temperature	°C	0 ... 120
Tightening torque	N·m	15
Degree of protection	IP65	
Acceleration error	mbar/g	<10
Service life	Typical	>10 <sup>7</sup>

<sup>1)</sup> Refer to table measuring chain

\*) Tightened to specified torque

## Dimensions

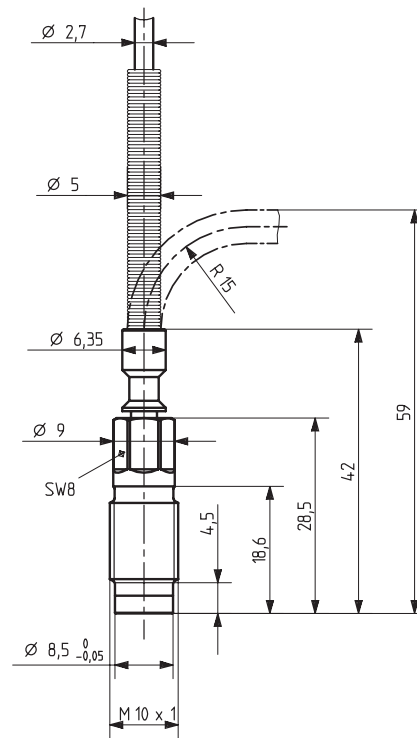

Fig. 1: Type 4067C3000...

## Installation

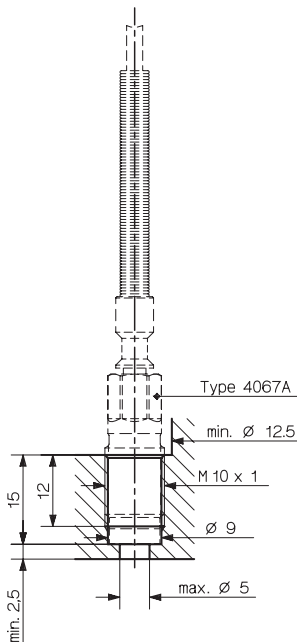

Fig. 2: Bore for direct mounting

### Hardened seal seat

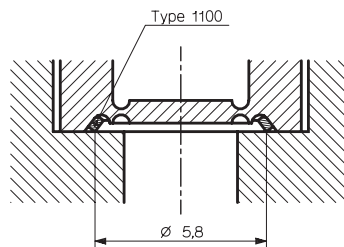

Fig. 3: Sealing with metal seal Type 1100

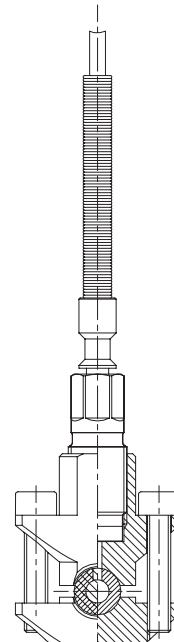

Fig. 4: Mounting in clamp adapter Type 6533A...

4067C\_000-708e-08.08

**Measuring Chain**

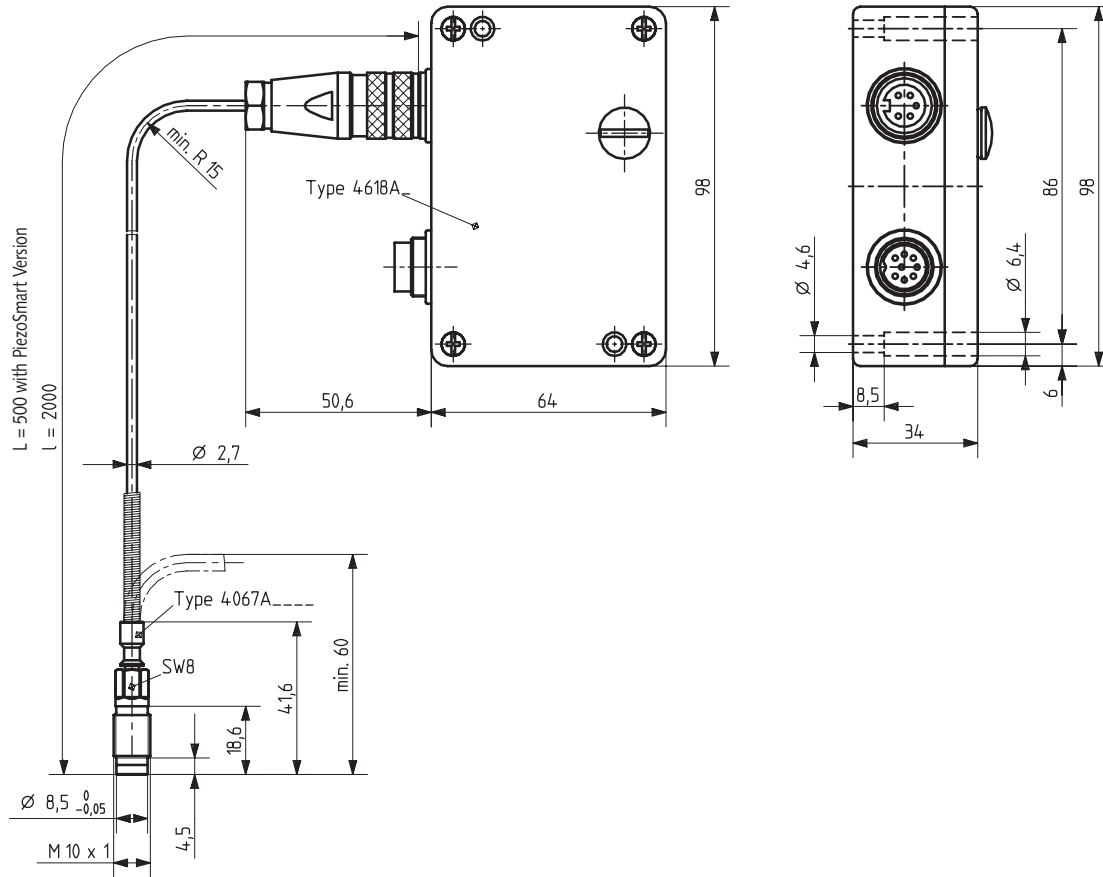

Fig. 5: Measuring chain

**Connector Pinout**

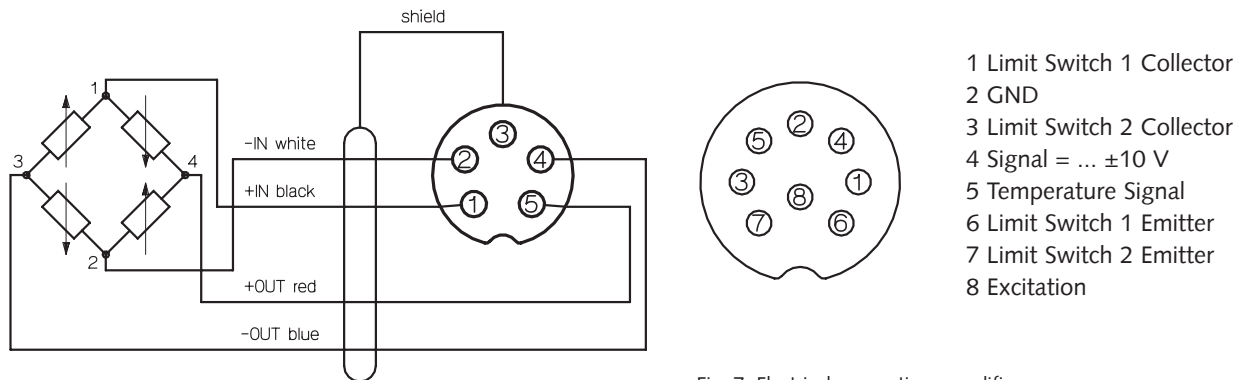

Fig. 6: Pin assignment

Fig. 7: Electrical connections amplifier

Connector Type 1500A81 is permanently fixed on the sensor cable (Fig. 8). The connector Type 1500A67 must be soldered to a suitable cable to supply the amplifier and for the signal and limit switch output (Fig. 9)

For more complete information on the amplifier Type 4618A... see data sheet 4618\_000-293.

4067C\_000-708e-08.08

## Accessories Included

The complete measuring chain

Type 4067C... includes the following components:

• Sensor with integrated cable	4067...
• Amplifier, adjusted	4618A...
• 8-pole connector for supply, output signal and limit switch	1500A57
• Spare sealing joints	1100

## Optional Accessories

• Extension cable	4757A...
• Drill	1327
• Sealing joint	1100
• Screw tap M10x1	1353
• Finishing tool	1300A25
• Mounting key for deep bores	1300A41
• Torque wrench	
4 ... 20 N·m	1300A39
8 ... 40 N·m	1300A11
• Fork wrench for Type 1300A39 or 1300A11, SW8	1300A29
• Fork wrench for Type 1300A39 SW9	1300A97
• Fork wrench for Type 1300A39 SW11	1300A75

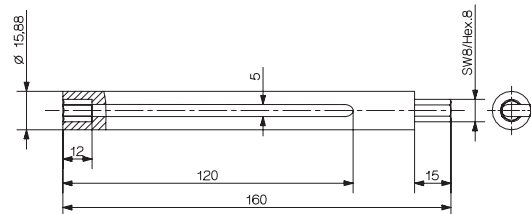

Fig. 8: Mounting key for deep bores Type 1300A41

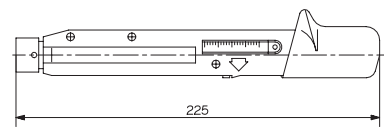

Fig. 9: Torque wrench Types 1300A11 and 1300A39

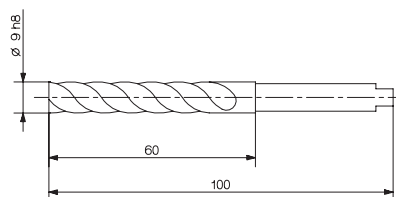

Fig. 10: Drill Type 1327

## Optional Accessories

• Dummy sensor	6449
• Clamp adapter for 6 mm line	6533A11
• Clamp adapter for 1/4" line	6533A12
• Clamp adapter for 6 ... 8 mm line	6533A18
• Clamp adapter for 8 ... 13 mm line	6533A19
• Clamp adapter for 13 ... 20 mm line	6533A110
• Adapter for Pressure generator	
Type 6906	6925
• Replacement sensors	see Page 3
• Replacement amplifier, adjusted	4618A...

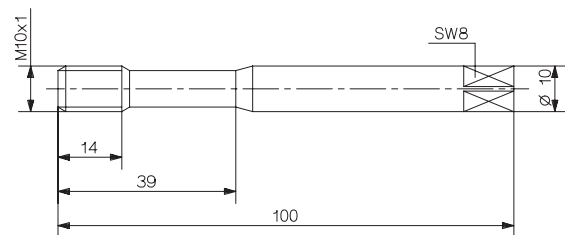

Fig. 11: Screw tap Type 1353

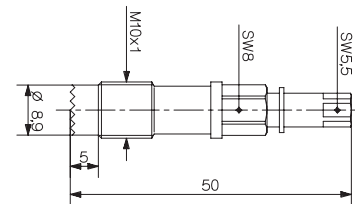

Fig. 12: Finishing tool Type 1300A25

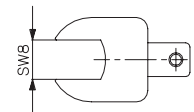

Fig. 13: Fork wrench Type 1300A29

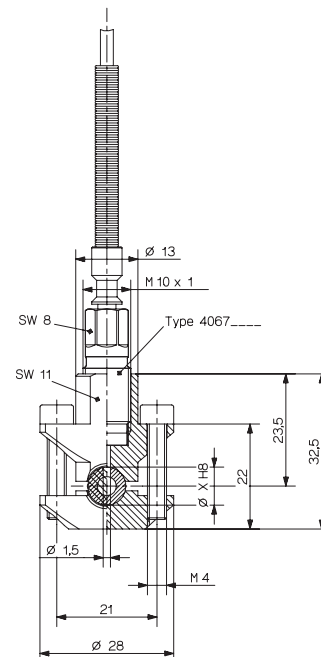

Fig. 14: Clamp adapter Type 6533A1...

## Ordering Key

### Measuring Chain

Type 4067C3000

#### Design

standard	-
metall tubing protected cable	V29

#### Signal Output

for pressure measurement 10 V and 4 ... 20 mA	A0
for pressure measurement (0 ... 10 V) and temperature measurement (10 mV/°C)	A2
for pressure measurement (4 ... 20 mA) and temperature measurement (10 mV/°C)	A4
for pressure measurement (10 V or 4 ... 20 mA) and temperature measurement (with Type 4620A2)	D2
with PiezoSmart <sup>®</sup> ) cable length L = 500 mm	S

#### Sensors

Sensor as replacement comes with calibration plug type 4958A0 or disk for digital compensation.

0 ... 3 000 bar                      Type 4067\_\_3000

#### Amplifiers

as replacement, adjusted to a given sensor (including Type 4958A)

for pressure measurement (0 ... 10 V) and (4 ... 20 mA)                      Type 4618A0

Sensors with temperature measurement have to be calibrated at our factory

for pressure measurement (0 ... 10 V) and temperature measurement (10 mV/°C)                      Type 4618A2

for pressure measurement (4 ... 20 mA) and temperature measurement (10 mV/°C)                      Type 4618A4

for pressure and temperature measurement with digital compensation                      Type 4620A2

\*) For PiezoSmart<sup>®</sup> specifications please refer to the PiezoSmart<sup>®</sup> brochure doc. no. 100-421.