

High Temperature Pressure Sensor

Type 4007B...

5 and 20 bar Version for Temperatures up to 200 °C

Rugged pressure sensor for the measurement of absolute pressures up to 20 bar and where close coupling of the sensor limits the size available for mounting.

- Operating temperature range from -40 to 200 °C
- Compact size (M5x0,5) and low mass
- Low acceleration sensitivity and high natural frequency
- Suitable for harsh environment
- Low thermal error due to digital temperature compensation

Description

The piezoresistive pressure sensor Type 4007B... is a small rugged high accuracy sensor capable of continuous high temperature operation up to 200 °C. Available in absolute pressure ranges up to 20 bar and designed for use in many varied applications but in particular where both the ambient and process temperatures are expected to be greater than 125 °C. The Type 4007B... utilizes a fully active four arm Wheatstone bridge to generate an electrical signal which is proportional to the applied pressure. The resistors making up the Wheatstone bridge are implanted into a micro-machined silicon diaphragm which is formed using Silicon on Insulator (SOI) technology. This approach, coupled with Kistler's DCE method of sensor construction, allows the 4007B... to be exposed to media temperatures in excess of 180 °C while minimizing hysteresis and repeatability errors. Further performance improvements are made using digital characterization techniques whereby, the effects of zero offset and sensitivity changes due to temperature can be reduced without sacrificing signal bandwidth.

The Sensor Type 4007B... is available in a number of variations including those that are suitable for use with Kistler Amplifiers Type 4665 and 4618A... . Equipped with PiezoSmart®, an active sensor identification system, it is possible to reduce set-up time and improve overall installation consistency when used in conjunction with the Amplifier Type 4665. When calibrated with a Type 4618A2 it is possible to monitor both the pressure signal and the sensor temperature via scaled electrical signals.

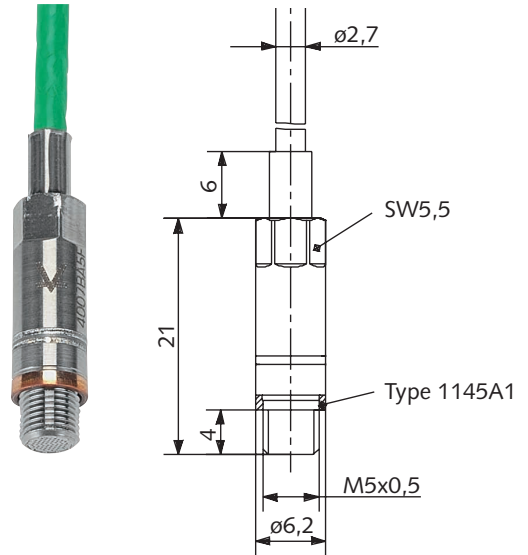

Application

The small size and excellent dynamic response of the Type 4007B... allows for high quality pressure measurements to be made in locations where other sensors may not fit. The measurement of high temperature gas pressure in gas turbines, powertrain development or environmental testing is well suited to this sensor.

4007B_000-614e-09_09

Technical Data

Type 4007B..., General

Measuring range	bar	0 ... 5	0 ... 20
Overload	bar	15	30
Power supply	mA*	1	
Output signal (FSO@1mA)	mV**	60 (nominal)	
Hysteresis	%FSO	<0,2	
Linearity***	±%FSO	<0,2	
Min./max. temperature	°C	-40 ... 200	
Natural frequency	kHz	>100	
Acceleration sensitivity	mbar/g	<0,1	
Internal dead volume	mm ³	40	
Clamping torque	N·m	1,5 ... 2,5	
Media compatibility		Liquids and gases compatible with parylene and 17-4 PH stainless steel	
Weight (connector inklusive)	g	50	

Type 4007B...S for SCP Amplifier Type 4665

Output signal	V	0 ... 10	
Sensitivity	V/bar	2	0,5
Hysteresis	%FSO	<0,2	
Sensitivity***	±%FSO	<0,1	
Operating temperature range Amplifier	°C	0 ... 60	
Thermal zero shift (0 ... 180 °C)	±%FSO	<1	
Thermal sensitivity change (0 ... 180 °C)	±%	<1	
Frequency range (-3 dB, measuring range)	kHz	0 ... 90	
Filter Settings		user-defined	
Power supply		integrated	
Electrical connection		Fischer connector S103A054	
Extension cable		Type 4761B...	

Type 4007B... with Amplifier Type 4618A... (Measuring Range)

Output signal pressure	V or mA	0 ... 10 V or 4 ... 20 mA	
Type 4618A0	mA		
Type 4618A2	V	0 ... 10	
Type 4618A4	mA	4 ... 20	
Output signal temperature			
Type 4618A2	mV/K	10	
Type 4618A4	mV/K	10	
Hysteresis	%FSO	<0,2	
Linearity***	±%FSO	<0,1	
Operating temperature range Amplifier	°C	0 ... 60	
Thermal zero shift (0 ... 180 °C)	±%FSO	<1,5	
Thermal sensitivity change (0 ... 180 °C)	±%	<1,5	
Frequency range (-3 dB, measuring range)	kHz	0 ... 40	
Filter settings		user-defined	
supply voltage	VDC	18 ... 30	
Electrical connection		Binder Connector pos. 5 pin, M16x0,75	

* For constant voltage excitation, please contact Kistler *** Max. deviation from best straight line (BSL)

** Alternative outputs available, please contact Kistler

Installation

The sensor can be easily mounted directly into a simple threaded measuring port. When measuring compressible media with high flow dynamics (such as intake pressure measurement in combustion engines), a flush mount configuration must be ensured (Fig. 1).

Mounting

The sensor fitting must be machined in accordance with the data sheet specifications (Fig. 5) and it is essential to comply with the tightening torque of 1,5 ... 2,5 N·m when installing the sensor. The use of the correct installation tools is also to be encouraged in particular the mounting tool Type 1300A12 (Fig. 9) and the torque wrench Type 1300A17 (Fig. 8).

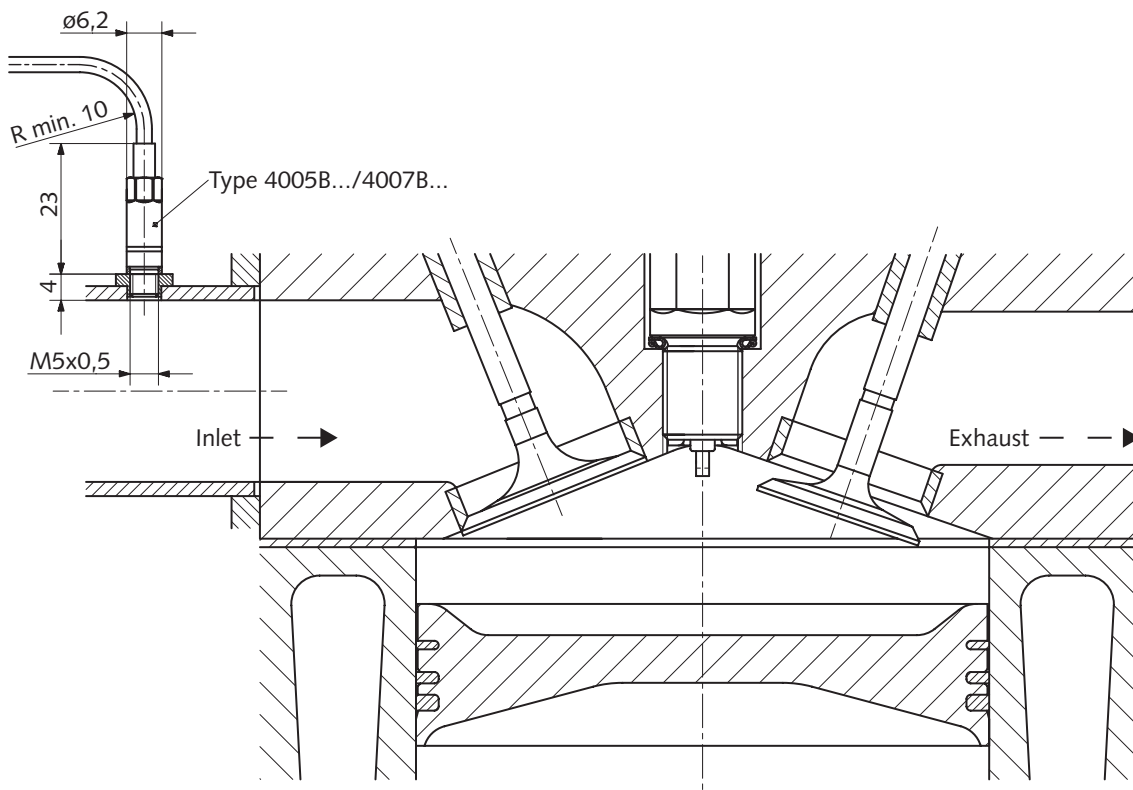

Fig. 1: Direct mounting of sensor Type 4005B.../4007B... in the intake manifold of an internal combustion engine

For more detailed instructions please see handout doc. no. 100-444.

Sensor Type 4007B...S for SCP Amplifier Type 4665 (with Connecting Cable Type 4761B...)

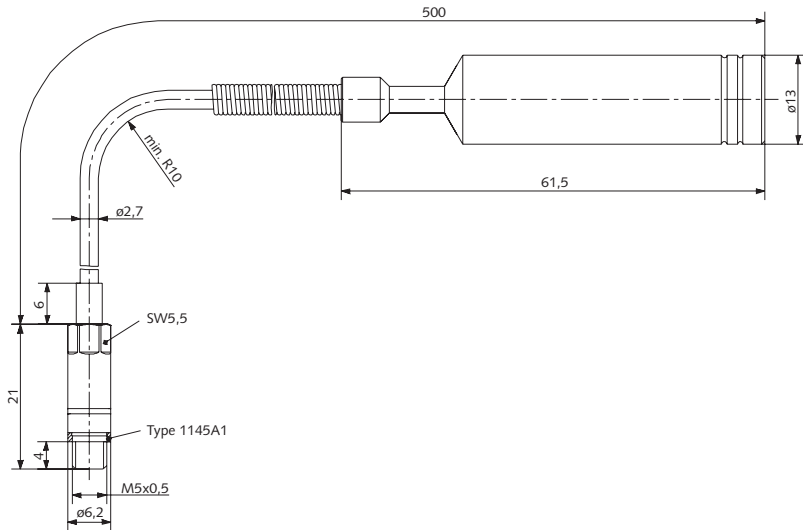

Fig. 2: Sensor Type 4007B... with Fischer connector

Sensor Type 4007B... with Amplifier Type 4618A... (Measuring Chain)

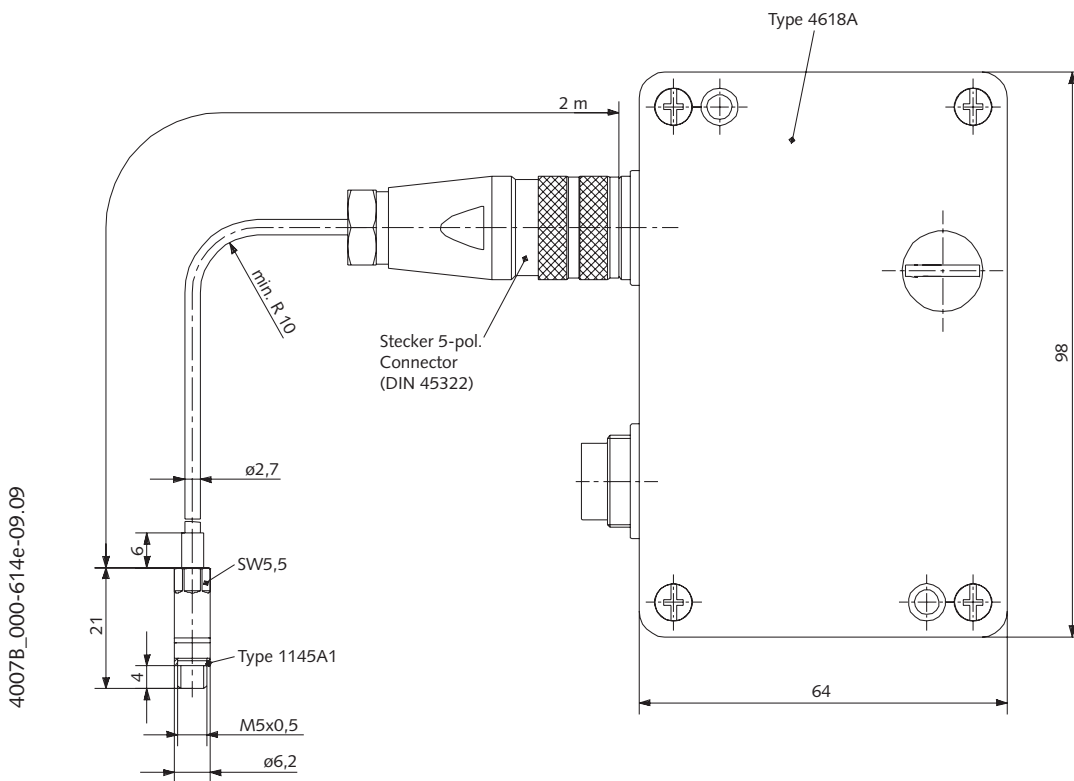

Fig. 3: Sensor Type 4007B... with amplifier Type 4618A...

4007B_000-614e-09_09

Included Accessories

- Copper seal

Optional Accessories

- Mounting tool
- Torque wrench 1 ... 6 N·m
- Teflon®-seal

Connecting cable for measuring chain with amplifier Type 4618

- L = 2 m
- L = 5 m
- L = ... m ($L_{\min} = 0,5/L_{\max} = 10$ m)

Connecting cable with amplifier Type 4665

- L = 2 m
- L = 5 m
- L = 10 m
- L = ... m ($L_{\min} = 0,5/L_{\max} = 10$ m)

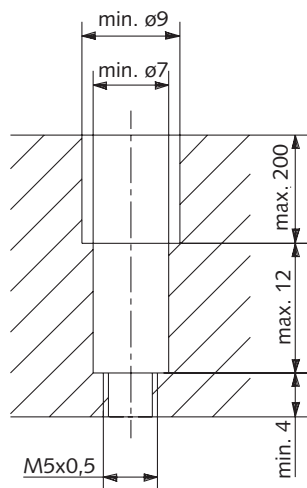

Fig. 4: Mounting bore for direct mounting

Type

1145A1

Type

1300A12

1300A17

1145A2

Optional Accessories

- SCP for 8 measuring modules

- SCP Compact for 4/6 measuring modules

- Piezoresistive amplifier

- Dummy sensor M5x0,5

- Adapter M14x1,25 – M5x0,5

- Adapter M12x1 – M5x0,5

- Cooling adapter

- Cooling adapter, damped

- Cooling adapter, damped

- Cooling adapter, damped

Type

2853A...

2854A...

4665

7537A2

6596

6598

7525A2

7525A6

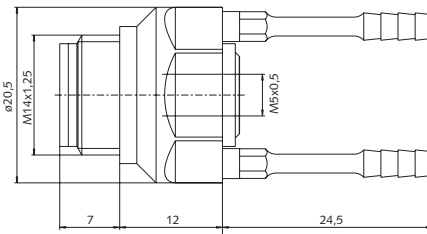

Fig. 6: Cooling adapter, damped Type 7525A6

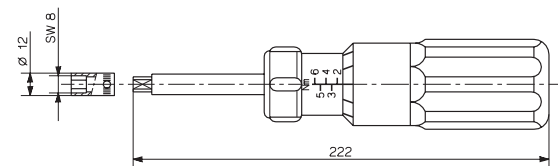

Fig. 7: Torque wrench 1 ... 6 N-m Type 1300A17

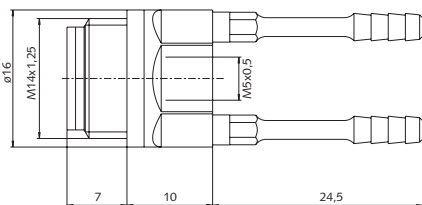

Fig. 5: Cooling adapter Type 7525A2

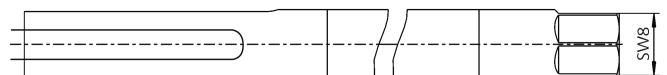

Fig. 8: Mounting tool Type 1300A12

Teflon® is a registered trademark of DuPont.

4007B_000-614e-09_09

Ordering Key

		Type 4007B			F	
Absolute pressure	A					
Measuring range 0 ... 5 bar	5					
Measuring range 0 ... 20 bar	20					
Thread						
Fine thread M5x0,5	F					
Amplifier Configuration						
Without amplifier with Fischer connector for amplifier Type 4665 (Data sheet 2854A_000-409)	S					
without amplifier with Binder connector for Type 4618A	-					
With amplifier Type 4618A0 with current signal (Data sheet 4618A_000-293)	A0					
With amplifier Type 4618A2 with temperature signal (Data sheet 4618A_000-293)	A2					

Ordering Example

	Type
Version with measuring range 0 ... 5 bar with amplifier Type 4665	4007BA5FS
Version with measuring range 0 ... 20 bar with amplifier Type 4618A2	4007BA20FA2

For more information, see PiezoSmart® system description, doc. no. 100-421.