

Reaction Torque Sensor

Type 9329A ... 9389A

–1 ... 1 N·m up to –1 000 ... 1 000 N·m

These easy to install piezoelectric reaction torque sensors are particularly suitable for measuring rapidly changing torques at non-rotating shafts. Five different size sensors are available for the measuring ranges ± 1 N·m, ± 10 N·m, ± 25 N·m, ± 200 N·m and $\pm 1\,000$ N·m.

- Two calibrated measuring ranges: 100 %, 10 %
- Very compact, ready to install reaction torque sensor
- Flexible adaption with mounting threads in double flange
- Centering seats for coaxial mounting and optimum introduction of torque
- Centric bore for shaft passage
- Can be used as torque calibration sensor

Description

The reaction torque sensor is integrated under high preload between preload screw and nut. When a torque acts on a sensor, the shear stresses produced are transmitted to the crystals. The charge signal proportional to the force is picked up by an electrode and fed through a screened cable to a charge amplifier. The charge signal is converted by the charge amplifier to a proportional output voltage, which can be recorded and evaluated.

Flanges on the top and bottom sides of the reaction torque sensor allow simple and direct installation on a shaft or adapter flange. This allows very low, space-saving installation. Alternatively, a mounting flange (optional accessories) can be used or installation can take place using custom adapters. A two-sided centering facility allows very accurate coaxial fitting. A centric bore allows additional applications, e.g. for shaft bushing. A screw-on connector cover ferrule is provided with the included accessories to protect the cable connection at the side.

Kistler reaction torque sensors reliably detect even the slightest torques acting on the sensor axis in both rotary directions.



Application

The sensor is suitable for measuring a dynamic or quasistatic torque acting on the sensor axis.

Examples of Application

- Torque setting of pneumatic screwdrivers
- Testing screw connections
- Calibration of manual torque wrenches
- Torque testing of springs
- Measurements on friction clutches
- Measurement of starting torques on electric motors
- Measurement of irregular rotation and torsional vibrations on small servo and stepper motors
- Testing of rotary switches (product testing)



Fig. 1: Reaction torque sensor with mounting flange

Dimensions Reaction Torque Sensor Type 9329A ... 9389A

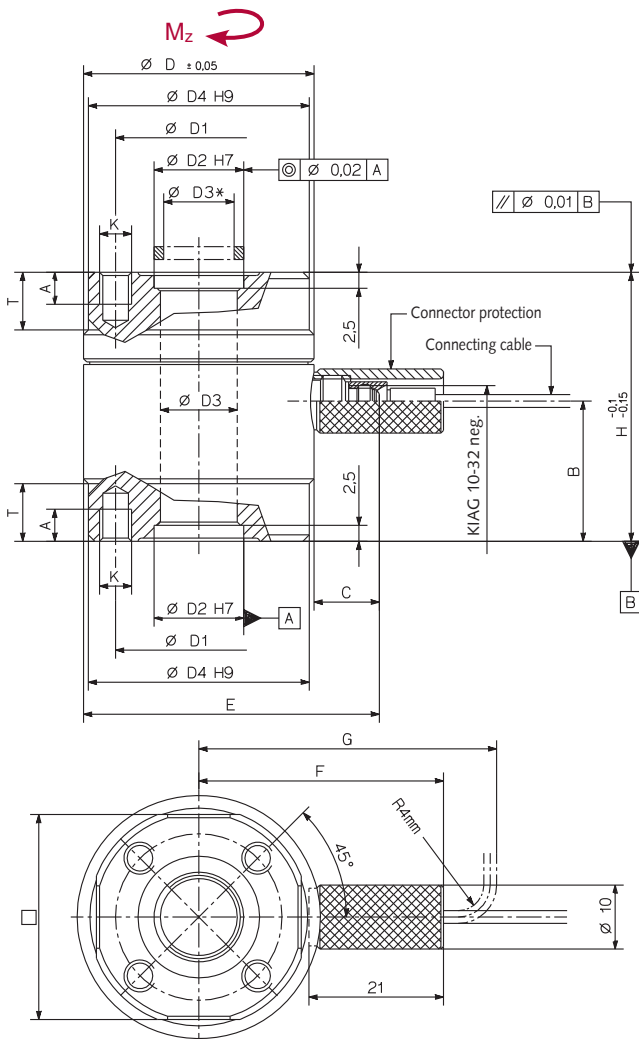

Fig. 2: Type 9339A ... 9369A with connector protection

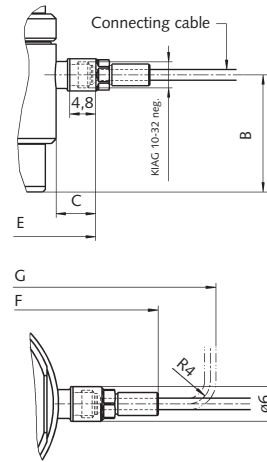

Fig. 3: Type 9329A

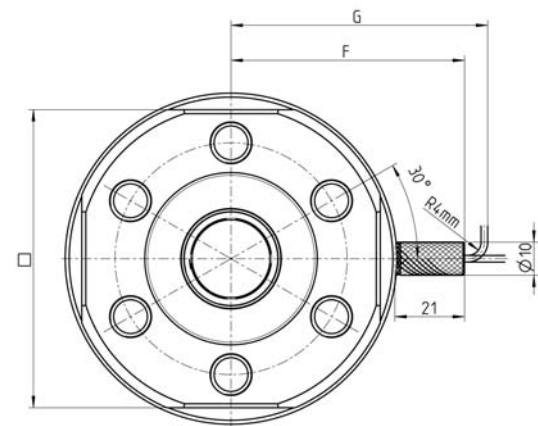

Fig. 4: Type 9389A with connector protection

Dimensions in mm

Type	D	D1	D2	D3	D3*	D4	H	A	B	C	□	E	F	G	K	T
9329A	20	14	6	4,4	4	19,5	26	3	13,2	7,4	17	27,4	-	36	M3	6
9339A	30	21	10	8,3	8	28,5	34	4	16,6	10,1	26	40,1	36	43,5	M4	8
9349A	36	26	14	11,7	11	34,5	42	5	21,7	10,2	32	46,2	39	46,5	M5	9
9369A	54	40	21	18,1	17	53	60	8	32,5	10,4	48	64,4	48	56	M8	13
9389A	100	70	30	24,5	23,5	98	130	14	69,2	10,4	90	110,4	70,4	80,5	M12	30

* Free access with mounted centering rings

9329A_000-463e-02.09

Technical Data

Reaction Torque Sensor		Type	9329A	9339A	9349A	9369A	9389A
Measuring range	M_z	N·m	-1 ... 1	-10 ... 10	-25 ... 25	-200 ... 200	-1 000 ... 1 000
Overload	M_z	N·m	-1,2/1,2	-12/12	-30/30	-240/240	-1 200 ... 1 200
Calibrated measuring ranges							
100 %	M_z	N·m	-1 ... 1	-10 ... 10	-25 ... 25	-200 ... 200	-1 000 ... 1 000
10 %	M_z	N·m	-0,1 ... 0,1	-1 ... 1	-2,5 ... 2,5	-20 ... 20	-100 ... 100
Threshold	M_z	mN·m	<0,03	<0,18	<0,35	<0,62	<0,78
Sensitivity		pC/N·m	≈-2 170	≈-460	≈-230	≈-130	≈-100
Linearity, all measuring ranges		%FSO	≤±0,2	≤±0,2	≤±0,2	≤±0,2	≤±0,2
Hysteresis, all measuring ranges		%FSO	≤0,3	≤0,3	≤0,3	≤0,3	≤0,3
Tensile/compression force, max.							
	F_z	kN	-3/9	-5/14	-10/8	-10/10	-60/60
Crosstalk	$F_z \rightarrow M_z$	mN·m/N	≤±0,01	≤±0,05	≤±0,01	≤±0,02	≤±0,01
Side force, max. ¹⁾	$F_{x,y}$ ($M_z = 100\%$; $F_z = 0$)	kN	0,47	0,38	0,44	0,27	3,66
Crosstalk (typical)	$F_{x,y} \rightarrow M_z$	mN·m/N	<0,5	<0,3	<0,3	<0,3	<0,2
Bending moment, max.	$M_{x,y}$ ($M_z = 100\%$; $F_z = 0$)	N·m	17,3	20	30	27	698
Crosstalk	$M_{x,y} \rightarrow M_z$	mN·m/N·m	<8	<8	<8	<12	<10
Rigidity	$c_\varphi (M_z)$	mN·m/μrad	≈17	≈96	≈189	≈924	≈1 540
Natural frequency (torsion) f_n		kHz	>53	>36	>33	>23	>11
Operating temperature range		°C	-20 ... 80	-40 ... 120	-40 ... 120	-40 ... 120	-40 ... 120
Temperature coefficient of sensitivity		%/°C	0,02	-0,02	-0,02	-0,02	-0,02
Insulation resistance at 20 °C		Ω	>10 ¹³	>10 ¹³	>10 ¹³	>10 ¹³	>10 ¹³
Capacitance		pF	≈73	≈43	≈340	≈350	≈910
Connection			KIAG 10-32 neg.				
Connector protector			no	yes	yes	yes	yes
Degree of protection (with cable connected)		EN60529	IP65				
Case material		DIN	1.4542				
Weight		g	50	137	243	800	6 720

¹⁾ Application of force in plane of flange

General

The torque should be introduced by the smallest possible eccentricity of the axes to be connected (<0,02 mm). Bending moment and shear forces should be avoided as far as possible.

The surfaces contacting the reaction torque sensor must be flat, rigid and clean. The centering facility on both sides of the reaction torque sensor using centering rings (included accessories) allow very accurate coaxial fitting.

The sensor can be fitted directly via the integral flanges on two sides. Special adapters can be manufactured for adaptation to the customer's specific applications.

Overview of Installation Variants

Adaption A: Installation in Shaft with Adapter for Shaft Journal with Pin

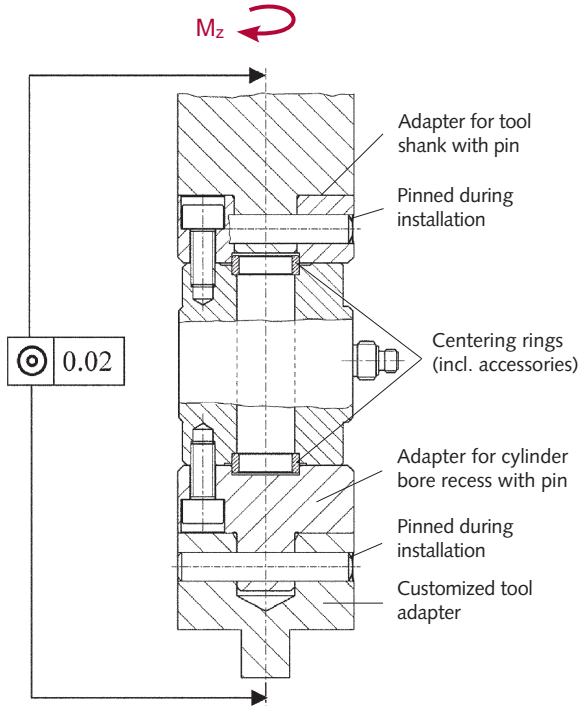

Adaption B: Installation in Shaft with Adapter Flange

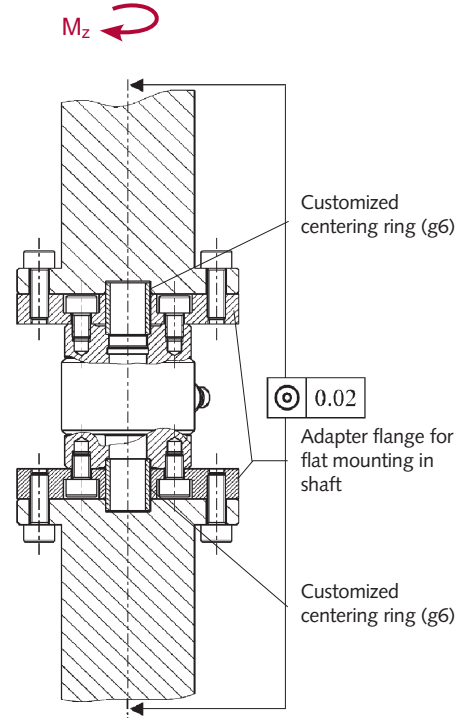

Adaption C: Installation with Shaft with Integrated Flange

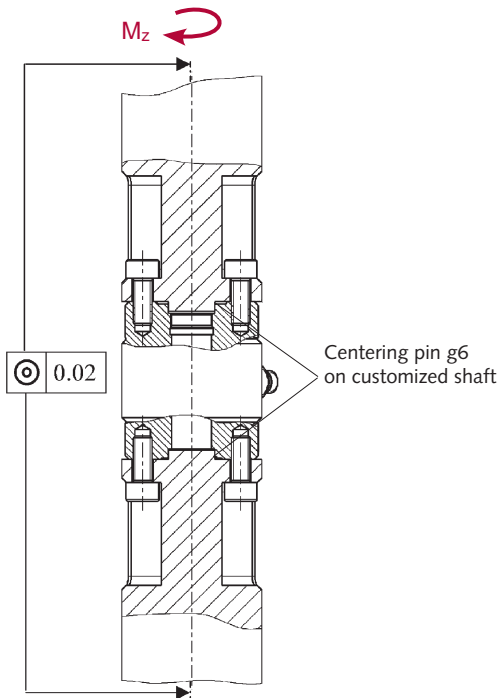

Adaption D: Adapter Flange for Wrenches with External Square Head

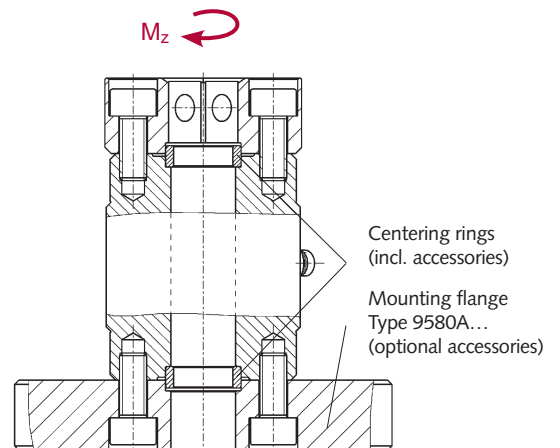

9329A_000-463e-02.09

Adaption E: Screw Plate with Spring Assembly

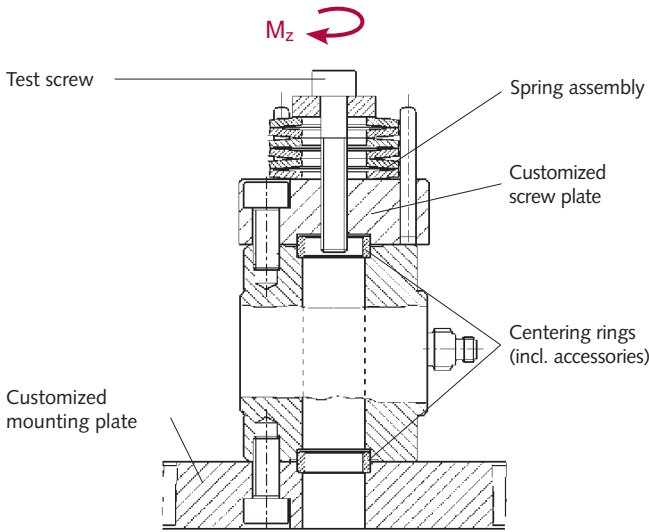

Adaption F: Desktop Installation with Mounting Flange

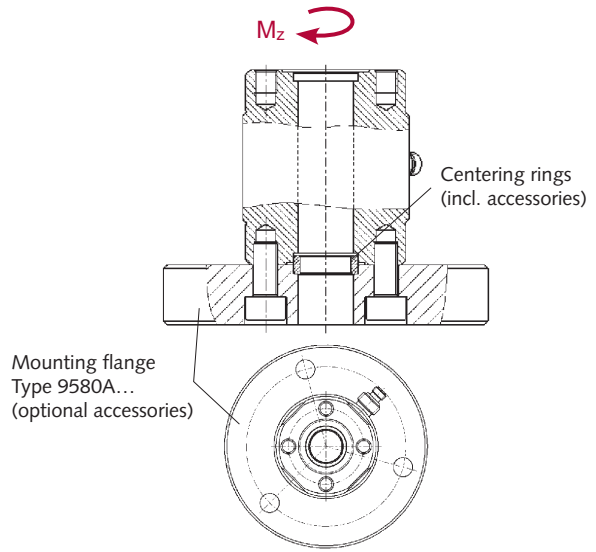

Ordering Key
Scope of Delivery Including Accessories

Reaction Torque Sensor	9329A
• 2 x Centering ring	3.420.196
Reaction Torque Sensor	9339A
• Connector protection	3.414.366
• 2 x Centering ring	3.420.179
Reaction Torque Sensor	9349A
• Connector protection	3.414.366
• 2 x Centering ring	3.420.180
Reaction Torque Sensor	9369A
• Connector protection	3.414.366
• 2 x Centering ring	3.420.181
Reaction Torque Sensor	9389A
• Connector protection	3.414.366
• 2 x Centering ring	3.420.197

Optional Accessories

• Connecting cable (see data sheet 1631C_000-346)	Type
• Mounting flange	9580A...

Mounting Flange

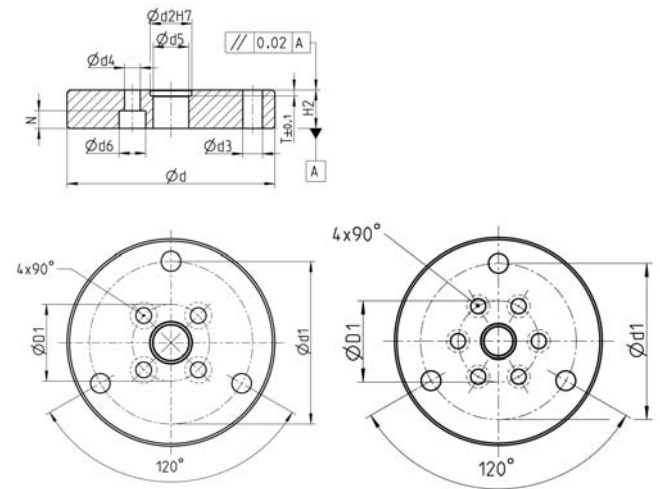

Fig. 5: Type 9580A9 ... A2

Fig. 6: Type 9580A4

for Type	Type	D1	d	d1	d2	d3	d4	d5	d6	H2	T1	N
9329A	9580A9	14	40	30	6	4,5	3,2	4,5	5,6	8	2	3
9339A	9580A0	21	62	50	10	5,5	4,3	8,5	7,5	11	2	5
9349A	9580A1	26	70	55	14	6,6	5,3	12	9	13	2	6
9369A	9580A2	40	100	78	21	13,5	8,4	18	14	22	2	9
9389A	9580A4	70	180	135	30	17	13	25	20	30	2,5	13

9329A_000-463e-02.09